

Notes:

# Aurora Design FMR-2

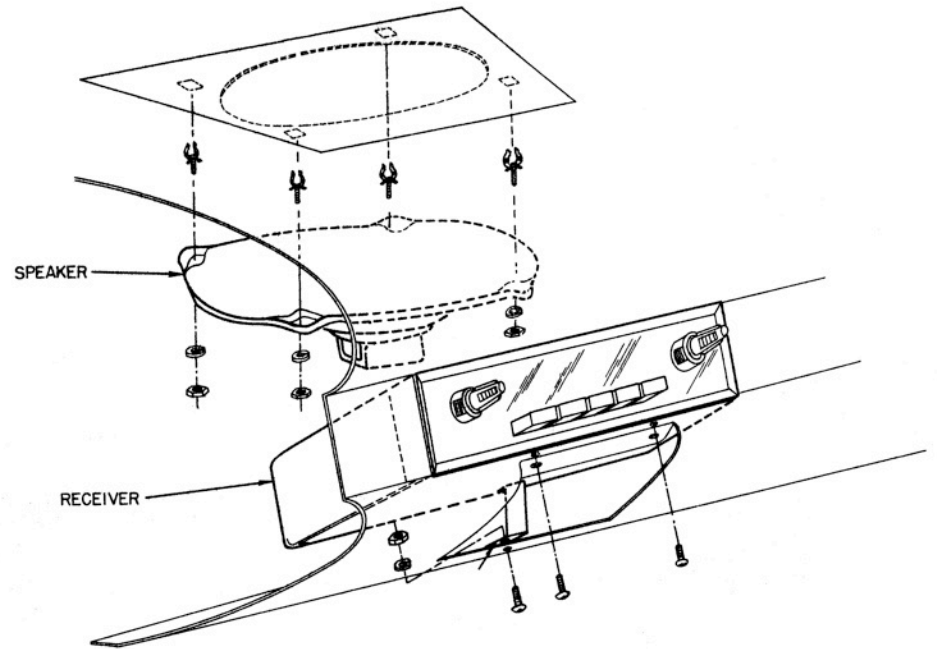

Dealer Name:

Date:

Job #:

## User Installation and Operation Manual

\*Subject to change without notice \*\*Characterized by component manufacturer

Aurora Design LLC. ©2013-17 Rev 2.2 5/17  
[www.tech-retro.com](http://www.tech-retro.com)

## *Your radio Configuration:*

- Tone Control - Original**
- Tone Control - External control**
- Tone Control - Using tone switch and volume control**
  
- Balance Control - Original**
- Balance Control - External control**
- Balance Control - Virtual**
  
- Fader Control - Original**
- Fader Control - External control**
- Fader Control - Virtual**
  
- AM/FM switching - Original**
- AM/FM switching - Power cycling**
  
- Aux Input selection - Tune to left side of dial**
- Aux Input selection - Signal sensing (VOX)**
- Aux Input selection - Power cycling**
- Aux input selection - External switch**
  
- American channels**
- Worldwide channels**
- Japanese channels**
  
- LED - Not Installed**
- RGB LED - AM/red FM/yellow Aux/green BT/blue USB/magenta**
- Bi-color LED - AM/red FM/yellow Aux/green BT-USB/orange**
  
- Tube Emulation Mode**
- Automatic Volume Control**
  
- Power - 12V negative ground, fused @ 12.5A max**
- Power - 12V positive ground, fused @ 8A max**
- Power - 6V negative ground, fused @ 12.5A max**
- Power - 6V positive ground, fused @ 8A max**
  
- Original Power lead**
- Red wire in cable harness**
  
- Original Dial lamp lead**
- Orange Dial lamp wire in cable harness**
- Dial lamp comes on with radio**

## *Specifications\*:*

### **FM Receiver:**

**Frequency Range:** 87.5-108MHz (Worldwide except Japan)  
76.0-90.0MHz (Japan)

**Channel Spacing:** 200kHz (America's)  
100kHz (all other regions)

**Sensitivity:\*\*** 5.0dB $\mu$ V @ 26dB SNR

**De-emphasis:** 75 $\mu$ S (America's)  
50 $\mu$ S (all other regions)

**SNR:\*\*** 60dB typ

**Image Rejection:\*\*** 60dB typ

**Audio Separation:\*\*** 40dB typ

**Audio Response:\*\*** 30Hz-15kHz -3dB

### **AM Receiver:**

**Frequency Range:** 530-1710 (America's)  
531-1611 (all other regions)

**Channel Spacing:** 10kHz (America's)  
9kHz (all other regions)

**Sensitivity:\*\*** 30dB $\mu$ V @ 26dB SNR

**SNR:\*\*** 56dB typ

**Image Rejection:\*\*** 55dB typ

**Speaker Impedance:** 2-32 $\Omega$

**Output Power:** 4 X 45W into 4 $\Omega$  @ 14.4V max (EIAJ)  
2 X 75W into 2 $\Omega$  @ 14.4V max (EIAJ)  
4 X 22W into 4 $\Omega$  @ 14.4V 1% THD  
2 X 40W into 2 $\Omega$  @ 14.4V 1% THD

### **Auxiliary Input:**

**Input Level:** -10dBV nominal level  
0dBV max without clipping

**Input Impedance:** ~5K $\Omega$

**Withstand Voltage:** +/- 24V max

### **Auxiliary Outputs:**

**Output Level:** 0dBV nominal level into 5K $\Omega$

**Frequency Response:** 10Hz-20kHz -1dB into 5K $\Omega$

## Troubleshooting:

**Low Power:** If the voltage to the radio drops to low for normal operation, the front panel LED will alternate between green and red and no audio will be heard until this situation is corrected.

**No Sound:** Make sure the radio is getting power. Check all fuses and wiring. Make sure speakers are properly connected and in good working order.

**Weak/Noisy Reception:** Make sure the antenna is connected to the radio and in good working order. The cable for the antenna can become damaged. Check for continuity between the center pin of the connector and the antenna mast. Also check for shorts between the center pin and the outer shield.

The FMR-2 uses sophisticated noise blankers to reduce or eliminate most engine/generator noise. If engine or generator noise is still present, investigate the cause of this noise, i.e. spark plugs and wires, generator/alternator suppression condensers etc.

**PowerOnDiagnostics:** Each time the radio is powered on it uses a sophisticated method to check the speaker outputs for problems. If found, the specific speaker channel is disabled and the error is reported on the front panel LED (if installed). The LED will flash a pattern similar to that used by the automotive ODB standard. The pattern consists of a number of flashes indicating which speaker followed by a short pause, then another set of flashes indicating the specific problem. If multiple faults are found, each of these patterns will be followed by a long pause and the next fault will be displayed.

First Group of Flashes	Second Group of Flashes
1 - Left Front Speaker	1 - Short to Ground
2 - Right Front Speaker	2 - Short to Battery
3 - Left Rear Speaker	3 - Line shorted together
4 - Right Rear Speaker	4 - Internal Error

**Overheating:** If the FMR-2 ever overheats in operation the front panel LED (if installed) will pulsate slowly. No damage will occur to the radio and it may start to lower the output power to bring the temperature back down. This should never occur in normal operation.

## Options:

If your radio was equipped with the BTU-2, BT-2 or USB-2 option cards, the radio will automatically mute the radio and switch to the option card when required. Please refer to the appropriate User Manual that came with the option card for complete information.

Congratulations on your new FMR-2 converted radio. With the FMR-2 installed in your radio you will experience unrivaled performance, features and reliability all while retaining the radios original appearance.

**Note:** Your radio was custom configured to your specifications. **All wiring and options listed in this manual may or may not be present on your radio. Please consult the *Configuration* and *Notes* sections of this manual for more information.** Contact your dealer with any questions about installation or operation of your radio.

## Installation:

Before starting installation you should remove one of the battery cables. Your radio came with a short 12 pin wiring harness. This harness will be used to connect the radio to your vehicle. The pinout is as follows:

Color	Signal	Color	Signal
Red	Ignition	Black	Ground
Blue	Switched Bat Out	Orange	Dial Lamp
White	Left Front+	White/Black	Left Front-
Grey	Right Front+	Grey/Black	Right Front-
Green	Left Rear+	Green/Black	Left Rear-
Violet	Right Rear+	Violet/Black	Right Rear-

The Red wire should be connected to an Ignition switched circuit that is fused as shown in the *Configuration* section of this manual. It should not be connected to a continuous battery circuit. The Black wire can be attached to a convenient point on the dashboard. The Orange wire should connect to the original dash lamp circuit. The Blue wire is a switched power output that can be used for power antennas, external amplifiers, etc. **Do not connect the Blue wire to battery!**

The remaining wires are for the speakers. To achieve such high power levels, the FMR-2 uses a bridged amplifier design where neither speaker lead is ground. Speakers with one side already grounded as used in some original applications must not be used. The FMR-2 performs best with speakers of 4 ohm impedance, a SPL rating of at least 90 dB and a power rating of at least 50W. The FMR-2 can also drive two 2 ohm speakers if four speakers are not possible in the vehicle. DO NOT connect four 2 ohm speakers. The FMR-2 can drive 1, 2, 3 or 4 speakers as follows:

For a 1 speaker installation the speaker can be connected to any one of the four outputs. The FMR-2 will detect that only one speaker is attached and enable mono mode while disabling the balance and fader controls.

For a 2 speaker installation, the speakers can be attached in one of three ways as follows:

- 1) If the two speakers are attached to either the front left/right pair or the rear left/right pair the FMR-2 will enable stereo mode and the balance control.

- 2) If one speaker is attached to the left or right front output and the other speaker is attached to the same channel (left or right) rear output, the FMR-2 will enable mono mode and the fader control.
- 3) If one speaker is attached to the left or right front output and the other speaker is attached to the opposite channel (right or left) rear output, the FMR-2 will enable stereo mode and the fader control.

For a 3 speaker installation, connect two speakers to the rear outputs and one speaker to the Left Front+ and Right Front- terminals.

For a 4 speaker installation all the speaker outputs will be used and the FMR-2 will enable stereo, balance and fader controls.

Note: when attaching a speaker output to an external amplifier, a 150 ohm 1 watt resistor needs to be connected across the output to tell the FMR-2 an external amplifier is attached to that output.

All unused wires should be taped up so they can't short out. The radio can now be mounted back into the vehicle and connected to the new wiring harness. Reattach the battery cable. Installation is now complete.

## ***Operation:***

Your converted radio will operate as before but with new performance and features.

**LED:** If your radio has a front panel status LED installed, it will display the current operating mode as for AM, FM, Bluetooth, USB, Auxiliary and Errors. The color of the LED for each mode will be as shown in the Configuration section of this manual.

**Mode Select:** Mode selection (AM, FM, Aux) varies depending on your radio configuration. In the following description, power cycling refers to quickly switching the radio off and back on. Each time this is done the radio will change to the next mode. The radio will always return to the last mode selected when first turned on.

If your radio has an AM/FM band switch, it will work as normal, otherwise AM/FM selection is done by power cycling.

The Auxiliary Input is selected by either tuning to the low end of the dial, automatically when a signal is sensed (VOX), or power switch cycling. Refer to the *Configuration* portion of this manual for information on how your radio was configured.

**Balance/Fader:** If your radio has balance/fader controls they will operate as before. If your radio does not have balance/fader controls, the FMR-2 enables virtual controls.

**Virtual Balance:** Quickly twist the tone control back and forth twice to the left. The tone control temporarily becomes the balance control. A tone will alternate between the left and right channels to verify you

have entered the virtual balance control. You may adjust the balance for as long as you wish. When finished, the FMR-2 waits a few seconds and then signifies that the setting was accepted by playing a tone. This setting is retained until it the next time it is changed.

**Virtual Fader:** Quickly twist the tone control back and forth twice to the right. The tone control temporarily becomes the fader control. A tone will alternate between the front and rear channels to verify you have entered the virtual fader control. You may adjust the fader for as long as you wish. When finished, the FMR-2 waits a few seconds and then signifies that the setting was accepted by playing a tone. This setting is retained until the next time it is changed.

**Loudness Contouring:** This is a method of contouring the audio spectrum to match that of the human ear. This should normally be enabled as it will make the audio sound more natural at all volume levels. To enable Loudness Contouring, quickly twist the tone control back and forth three times to the left. An ascending tone will be heard. To disable Loudness Contouring and provide a flat frequency response, quickly twist the tone control back and forth three times to the right. A descending tone will be heard.

**Tone Switch:** If your radio has a tone switch rather than a tone control it may have been configured to select between volume and tone functions on the main volume control. In one position of the tone switch, the volume control will function as normal. In the other position of the tone switch it will function as the tone control with full compatibility with the virtual controls as described above. When you switch from volume to tone, the FMR-2 will hold the volume steady until you return to the volume position of the tone switch. Since it is possible the volume control could now be set to a very high volume depending on where it was left after making adjustments to the tone and virtual controls, the FMR-2 will beep once to alert you of this condition, and the volume control will need to be lowered to at least the previous level before it will start operating normally again. Also if the tone switch is set to the tone position when the radio is first turned on, the volume will be at a safe, preset level so that it will not damage the speakers.

**Tuning:** Your radio will tune as before including pushbuttons and automatic Signal Seeking operation. Pushbuttons can be set for an AM or FM station (radio must be in correct band mode for button).

Signal Seeking radios like the Wonderbar®, Town & Country and ElectroTouch will operate as before including sensitivity (Town/Country) controls. A Scan feature is also provided by quickly pressing the Seek button twice. The radio will scan to the next station, pause and then continue to the next station until the Seek button is pressed again. The front panel status LED will slowly pulsate while in the Scan mode.

**Line Out:** Optional Line Out jacks may have been added to your radio if requested. The five outputs (front/rear pair and subwoofer) can be attached to an outboard amplifier. These outputs are post pre-amp and are affected by the controls on the radio.