

A U R O R A
D E S I G N

World Converter

Model WC-01

User and Technical Manual

Copyright 2008-10 Aurora Design LLC.
Revision 2.0
26 August, 2010
All specifications subject to change
www.tech-retro.com

Introduction

This manual covers the operation and technical aspects of the Aurora Design World Converter. This Converter is designed to accept any standard color NTSC, PAL or SECAM video signal and convert to one of many different output standards, both electronic and mechanical.

Features

- Compact, low power, surface mount design
- Front panel 20 character / 2 line high contrast LCD and rotary encoders
- Agile built-in RF Modulator:
 - Programmable between 28.5-880MHz
 - Supports positive/negative video and AM/FM audio modulation schemes
 - Preprogrammed with 31 RF Systems and over 800 channels
 - Custom User configurable RF System with up to 32 unique channels
- Converter bypass mode for use as stand alone RF Modulator
- Extremely stable output: +/- 3% levels, +/- 50ppm timing
- Extremely accurate algorithms used for conversions:
 - Three line interpolation on all electronic standards
 - All internal calculations done to a minimum 14 bit precision
- 10 bit professional grade video decoder
- 2 high speed 12 bit video D/A's for greater than 66dB dynamic range
- 3 medium speed 12 bit video D/A's for mechanical RGB output
- 4 low speed 12 bit D/A's for system control
- 512Mb or 1.0Gb FLASH Image Memory for storing of custom images
- 128Mb SDRAM holds eight 10 bit images with 63 mega-pixel/sec performance
- 500K gate equivalent, 300Kb RAM FieldProgrammableGateArray
- 4Mb EEPROM memory for FPGA firmware, field upgradeable
- 8 bit microcontroller with 64K FLASH memory for system control, field upgradeable
- Custom microcontroller RTOS
- 512Kb EEPROM memory for storing all user settings
- 20 bit audio codec for extremely high quality audio
- All outputs fully buffered
- 5 separate switching supplies for high efficiency, low power operation

- Full compliment I/O:
 - Composite Video Input (NTSC/PAL/SECAM, 1Vpp, 75Ω)
 - S-Video Input (NTSC/PAL/SECAM, 1Vpp, 75Ω)
 - Component Video Input YUV/RGB/RGBS (NTSC/PAL, 1Vpp, 75Ω)
 - Composite Video Output (1Vpp, 75Ω)
 - Mechanical RGB Output (1Vpp, 75Ω)
 - Stereo Audio Inputs (-10dBV nominal, 0.2Vpp-5Vpp, 20KΩ)
 - Mono Audio Output (-10dBV nominal, 0.2Vpp-5Vpp, 100Ω)
 - Reference Input (20Vrms maximum, 0.0-3.0V threshold, 10KΩ)
 - Reference Output (3.3Vpp maximum, 75Ω)
 - RF Output (66dBμV-98dBμV adjustable, 75Ω)
 - DC Power Input (7.5-20Vdc, 3W typical)
 - DC Power Switched Output (4A maximum)
 - Reference Driver Output (optional, 20W maximum into 8Ω)
 - Mechanical RGB Driver Output (optional, 20W maximum total)

Front Panel

The front panel is shown below:

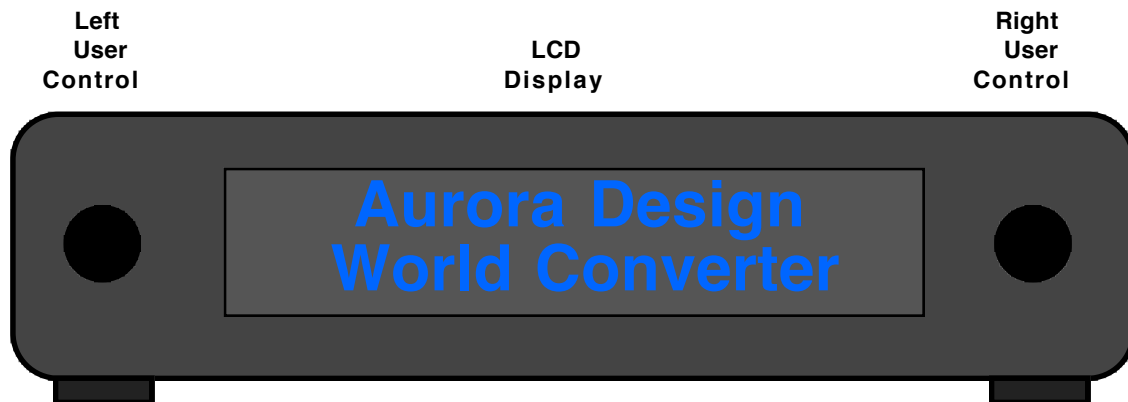

Left/Right User Controls:

These two rotary encoders are used to control all aspects of the converter. By default, the left encoder is the Menu Control, and the right encoder is the Select

Control. (This can be changed in the *System Settings Menu*) These controls can be rotated in either direction, and pushed to make selections. The converter is powered on and off by holding both these controls in for 1 second.

LCD Display:

This high contrast, 20 character, 2 line display is used to make all changes, and to display status of the converter. The top line is used to display the menu or setting that is currently selected, while the second line displays the actual setting.

Rear Panel

The rear panel is shown below:

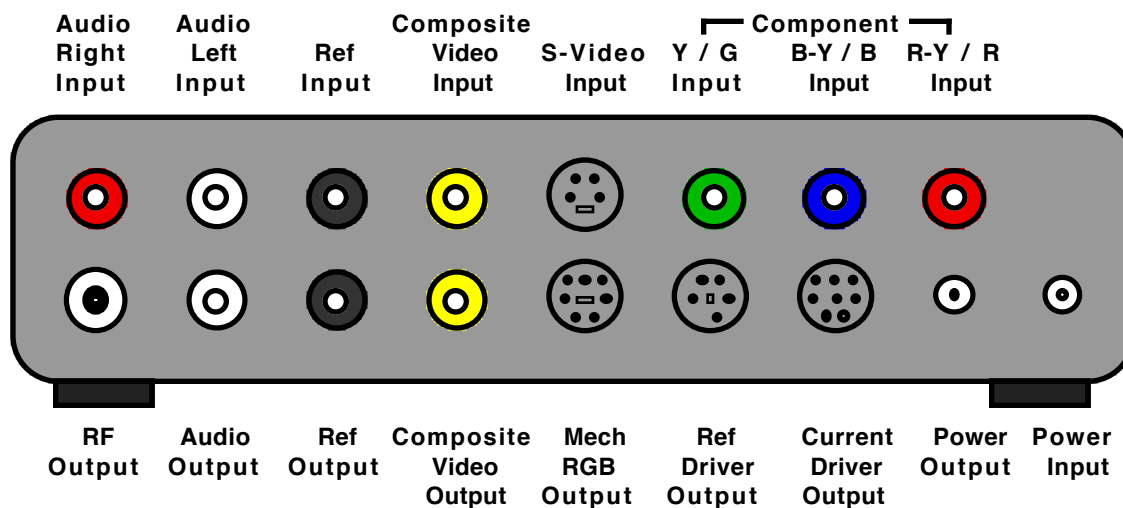

Audio Right/Left Inputs:

These RCA connectors are used to supply the audio signal to the converter. The two connectors are summed internally into a monaural signal with a selectable gain. (adjusted in the *Input Settings Menu*) If only a monaural source is available, it can be connected to either of the audio input connectors, or both through a “Y” cable if higher input gain is required. The inputs can accept a wide range of audio input levels, but are designed to work optimally with standard, consumer level -10dBV audio signals. For complete information about the characteristics of these inputs, please refer to the *Specifications* section found later in this manual.

Ref Input:

This RCA or BNC connector is used to supply a reference signal to the converter for mechanical standards. The signal can be a Line, Frame or Mains reference. The input is DC coupled internally, and has an adjustable threshold settable in the *Output Settings Menu*. This input is set to *Auto Detect* mode by default, and does not normally need to be changed. For complete information about the characteristics of this input, please refer to the *Specifications* section found later in this manual.

Composite Video Input:

This RCA or BNC connector is normally used to supply a composite NTSC, PAL or SECAM video signal to the converter. The input is set to *Auto Detect* by default, but can be overridden in the *Input Settings Menu*.

In addition, if the converter is set to the *Bypassed* mode, then the video signal on this connector is sent to the RF modulator with no additional signal processing. Any video signal can be supplied in this mode, although it is the users responsibility to verify this video signal to obtain the desired result from the modulator. For complete information about the characteristics of this input, please refer to the *Specifications* section found later in this manual.

S-Video Input:

This Mini-DIN connector is used to supply an S-Video NTSC, PAL or SECAM signal to the converter. This input provides a higher quality signal than the composite input and should be used if available. The input is set to *Auto Detect* by default, but can be overridden in the *Input Settings Menu*. For complete information about the characteristics of this input, please refer to the *Specifications* section found later in this manual.

Component Video Input:

These RCA or BNC connectors are used to supply a component NTSC or PAL video signal to the converter. This input provides the highest quality signal and should be used if available. The input is set to *Auto Detect* by default, but can be overridden in the *Input Settings Menu*.

The component video signal can be of the type YUV, RGB or RGBS. (with RGBS the composite video input is used for the S signal). Only a YUV type signal will be recognized in the *Auto Detect* mode. If an RGB or RGBS source is used, it must be manually selected in the *Input Settings Menu*. For complete information about the characteristics of this input, please refer to the *Specifications* section found later in this manual.

RF Output:

This F connector provides the RF output from the modulator. This output should terminate into a 75Ω load. It should only be used to connect directly to the antenna terminals of a television set, and never be used for broadcast purposes. The RF System, RF channel and output gain on this connector can be selected in the *Output Settings Menu*. For complete information about the characteristics of this output, please refer to the *Specifications* section found later in this manual.

Audio Output:

This RCA connector provides the processed audio output from the converter. This output is delayed to match the video output of the converter. For complete information about the characteristics of this output, please refer to the *Specifications* section found later in this manual.

Ref Output:

This RCA or BNC connector provides a reference signal from the converter. For electronic standards, this can be a Field or Frame pulse, while for mechanical standards it can be a Line, Field or Mains reference. In addition, the audio output can be routed through this connector, and when used in conjunction with the optional Reference/Current Driver option, can provide a signal to directly drive a loud speaker. This is beneficial when used with mechanical televisions that normally do not have audio facilities. For complete information about the characteristics of this output, please refer to the *Specifications* section found later in this manual.

Composite Video Output:

This RCA or BNC connector provides the video output from the converter. This signal should terminate into a 75Ω load. This output is the main video output from the converter and is only valid when the converter is not set to *Bypass* mode. If the converter is set to *Bypass* mode, no signal will be present at this output. For complete information about the characteristics of this output, please refer to the *Specifications* section found later in this manual.

Mechanical RGB Output:

This Mini-DIN connector provides an additional, simultaneous RGB output signal for all mechanical standards. These signals should terminate into a 75Ω load. While

the monochrome output will still be present on the composite video output, this connector provides three separate outputs that contain the color information. For mechanical standards that contain sync information, like that of the NBTV, the sync information will not appear at this output, only on the composite output. For complete information about the characteristics of this output, please refer to the *Specifications* section found later in this manual.

Ref Driver Output (optional):

When the optional Reference/Current Driver board is installed, this Mini-DIN connector will provide a 20W output of the signal on the *Ref Output*. This can be used to drive phonic coils on mechanical televisions with the appropriate matching transformer, or drive a loud speaker in *Audio Passthrough* mode. For complete information about the characteristics of this output, please refer to the *Specifications* section found later in this manual.

Mechanical Current Driver Output (optional):

When the optional Reference/Current Driver board is installed, this Mini-DIN connector will provide three 333ma LED current drivers of the signals on the *Mechanical RGB Output*. These three outputs can directly drive an RGB LED array for full color mechanical television, or can be bridged together to drive a monochrome LED array. For complete information about the characteristics of this output, please refer to the *Specifications* section found later in this manual.

Power Output:

This DC coaxial connector is a switched output of the Power Input connector, and used to supply power to external devices. It can be enabled in the *Output Settings Menu*. For complete information about the characteristics of this output, please refer to the *Specifications* section found later in this manual.

Power Input:

This DC coaxial connector is used to supply power to the converter. The amount of power required is determined by the options and load connected to the converter. Voltages in excess of those shown in the *Specifications* section can result in damage to the unit. For complete information about the characteristics of this input, please refer to the *Specifications* section found later in this manual.

Menus

The basic menu structure is shown below: (Also see *Appendix A*)

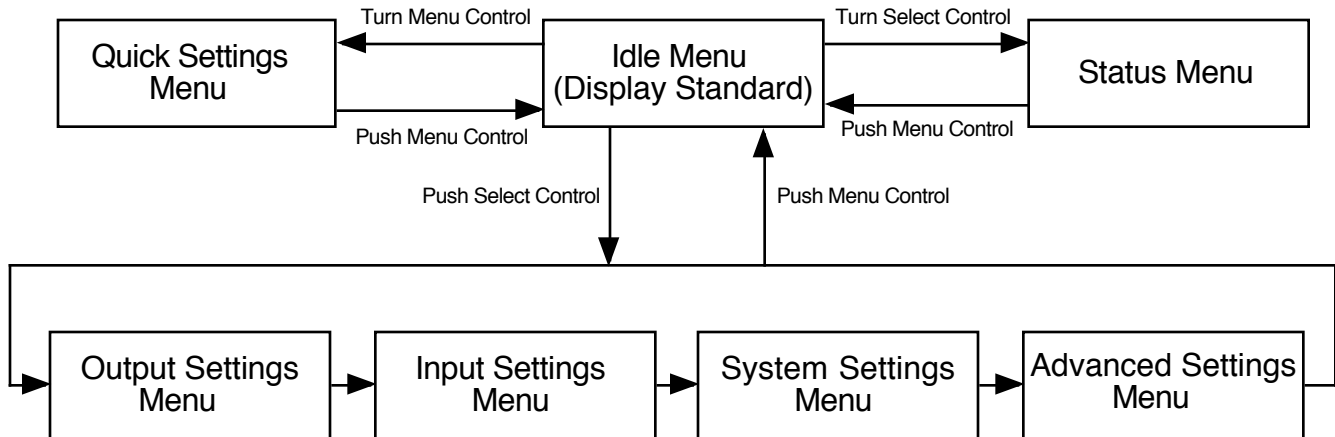

Overview:

As a general rule, the Menu Control is used to scroll through the current level menus, and by pushing the control, pop up to the previous menu. The Select Control is used to scroll through the current settings, and by pushing the control, select the current setting or menu.

The exceptions to this rule are when the converter is in the Idle Menu. From this menu, the Quick Settings Menu is entered by turning the Menu Control. This is where the most often used user settings are. Turning the Select knob from the Idle Menu enters the Status Menu where various system status information can be displayed. By default, all menus will timeout and return to the Idle Menu if no Control is adjusted for one minute.

Most user settings are automatically saved in the user EEPROM when they are changed by the user. The changes are updated instantaneous in the converter. There are a few exceptions to this rule which require the user to push the Select Control to accept the change. For instance, when swapping the functionality of the front panel Controls, it would be confusing to make the changes instantaneous, so the user is required to push the Select Control to make the change active. If the user changes menu without pushing the Select Knob, then any setting changes will be disregarded, and the converter will continue to operate with the original settings. These exceptions will be pointed out below, and will be designated with a question mark on the LCD screen of the unit.

Note: All settings are factory defaulted to the most appropriate values for each standard. Typically the converter can be used with no other selections than the output standard. The defaults can be restored at any time through the *Advanced Menu*.

Idle Menu:

This is the highest level menu, and is the menu the converter enters on power up or when inactive. It displays the current output standard. No user settings are available in this menu, but all other menus are entered from this state.

Output Settings Menu:

This menu is entered from the *Idle Menu* by selecting it with the Select Control. Once in the *Output Settings Menu*, all specific aspects of an output standard are set. All settings in this menu are unique for each standard, so making a change in one standard will not affect other standards. The following submenus are available from the *Output Settings Menu*:

Output Standard:

This submenu is always available, and is used to select the desired output standard. When an output standard is selected, all previous user settings for that standard are restored. Note that this setting purposely takes 2 seconds to become active. This was done to eliminate erroneous outputs while scrolling through the output standards. For complete list of available output standards, please refer to the *Supported Output Standards* section found later in this manual.

RF System:

This submenu is only available when an electronic standard is currently active. The desired *RF System* to be used for the RF Output is selected in this submenu. The *RF System* along with the country it is most often used will be displayed on the front panel LCD. For complete list of available output standards, please refer to the *Supported RF Systems* section found later in this manual.

RF Channel:

This submenu is only available when an electronic standard is currently active, and

an *RF System* is selected. The desired *RF Channel* to be used for the RF Output is selected in this menu. Any of the defined channels for the selected *RF System* can be selected in this submenu. For complete list of available output standards, please refer to the *Supported RF Systems* section found later in this manual.

RF Gain:

This submenu is only available when an electronic standard is currently active, and an *RF System* and *Channel* is selected. The desired RF Gain between -12dB and +20dB is selected in this submenu. Selecting too high of an output gain can overdrive some televisions and result in a distorted signal, however a high output level can be fed into a passive antenna splitter and used to feed multiple sets.

Color Type:

This submenu is only available when an electronic standard that is color capable is currently active. The available color types for the current output standard will be selected in this submenu. These will typically be of the type NTSC, PAL, SECAM, RGB Sequential, etc.

Ref Input Type:

This submenu is only available when a mechanical standard is currently active. The possible selections are:

- Disabled* - Reference input is ignored
- Auto Detect* - Converter will automatically determine the type of the source
- Line Reference* - Only a Line Reference will be recognized
- Frame Reference* - Only a Frame Reference will be recognized
- Mains Reference* - Only a Mains Reference will be recognized

The reference input is used to synchronize the converter to an external source. This input is DC coupled and conditioned, and will accept any signal up to 20Vrms. The signal must be within +/-5% of the expected value to be recognized.

Ref Input Threshold:

This submenu is only available when a mechanical standard is currently active, and the *Ref Input Type* is not disabled. It is used to select the threshold trigger level of the reference input from 0.0V to 3.3V.

Ref Output Type:

This submenu is always available and is used to select the *Reference Output Type*. The possible selections are:

- Disabled* - No Reference Output
- Line Pulse* - Line square wave
- Line Sine* - Line sine wave (mechanical only)
- Frame Pulse* - Frame square wave
- Frame Sine* - Frame sine wave (mechanical only)
- Mains Pulse* - Mains frequency square wave (mechanical only)
- Mains Sine* - Mains frequency sine wave (mechanical only)
- Red Field Pulse* - Red field ID pulse (sequential electronic standards only)
- Green Field Pulse* - Green field ID pulse (sequential electronic standards only)
- Blue Field Pulse* - Blue field ID pulse (sequential electronic standards only)
- Audio Passthrough* - Passes audio output through reference output (only with Reference Driver Board option installed)

For electronic standards the pulse outputs can be used to trigger an oscilloscope or external device to synchronize it with the converter. For mechanical standards, the Line, Frame, or Mains output can be used to drive a phonic coil, synchronous motor, or other synchronizing device.

Ref Driver:

This submenu is only available when the optional Reference/Current Driver Board is installed. The output level can be selected in this submenu from *Disabled* to *100%*. Since the Reference Driver Board gets its signal from the *Reference Output*, this setting also affects the *Reference Output* level. For complete information about this submenu, please refer to the *Reference/Current Option* section later in this manual.

Mech Current Driver:

This submenu is only available when the Reference/Current Driver Board is installed and a mechanical standard is currently active. This submenu selects the current level of the three LED drivers. The possible selections are:

- Disabled* - Current outputs shut off
- 50ma/Channel* - 50ma for each channel or 150ma when bridged
- 75ma/Channel* - 75ma for each channel or 225ma when bridged
- 100ma/Channel* - 100ma for each channel or 300ma when bridged
- 150ma/Channel* - 150ma for each channel or 450ma when bridged
- 225ma/Channel* - 225ma for each channel or 675ma when bridged
- 333ma/Channel* - 333ma for each channel or 1000ma when bridged

The *Mechanical Driver Output* has a detection system that senses what is plugged into the connector, and only allows the selections appropriate for the device. For instance, if a monochrome LED array is connected, you would not be able to select a color output. If a color LED array capable of 100ma/Channel maximum is connected, than no setting above 100ma/Channel is possible. For complete information about this submenu, please refer to the *Reference/Current Option* section later in this manual.

Gamma Correction:

This submenu is only available when a mechanical standard is currently active. Gamma correction is required since standard video is pre-corrected for the characteristics of a CRT, and is not compatible with LED or NEON lamps used in mechanical television. If the device the converter is driving already has gamma correction built in, then it can be disabled in the converter.

Output Polarity:

This submenu is always available and is used to select the polarity of the video output. Normally this should be set to Positive. If the device the converter is driving requires an inverted video signal, this submenu can be set to Negative.

Line Scan:

This submenu is always available and is used to select the Line scan direction. When set to *Normal*, the Line scan will be in the direction appropriate for the selected standard. If the device the converter is driving has the direction reversed, such as in an electronic television with the scan coils reversed, or a mechanical set with the motor running in the wrong direction, this can be set to *Reversed*.

Frame Scan:

This submenu is always available and is used to select the Frame scan direction. When set to *Normal*, the Frame scan will be in the direction appropriate for the selected standard. If the device the converter is driving has the direction reversed, such as in an electronic television with the scan coils reversed, or a mechanical set with the motor running in the wrong direction, this can be set to *Reversed*.

Switched Power:

This submenu is always available and is used to enable the *Switched Power Output*

connector on the converter. If an external device is attached to the converter that requires power, it can be enabled when the appropriate output standard is selected.

Input Settings Menu:

This menu is entered from the *Idle Menu* by selecting it with the Select Control. Once in the *Input Settings Menu*, specific aspects of the inputs to the converter are set. Settings in this menu are system wide. The following submenus are available from the *Input Settings Menu*:

Audio Gain:

This submenu is used to set the gain of the audio inputs. The gain can be varied from -12dB to +12dB. Additionally this menu shows if the input and/or output digital data is being clipped by displaying an “*In*”, “*Out*” or “*I&O*” after the word “*Clip*”. The gain should be adjusted in this submenu, or at the source so that neither the input or output is clipping.

Video Brightness:

This submenu is used to set the brightness of the video input decoder. It is adjustable from -50 to +50 IRE. This can be used to correct for a poor or out of spec video input signal.

Video Contrast:

This submenu is used to set the contrast of the video input decoder. It is adjustable from 0.000 to 1.995. This can be used to correct for a poor or out of spec video input signal.

Video Chroma:

This submenu is used to set the chroma gain of the video input decoder. It is adjustable from 0.000 to 1.995. This can be used to correct for a poor or out of spec video input signal.

Video Hue:

This submenu is used to set the hue of the video input decoder. This setting only affects NTSC signals on the composite and S-Video inputs. It is adjustable from -90 to +90 degrees. This can be used to correct for a poor or out of spec video input signal.

Video Sharpness:

This submenu is used to set the Luma Sharpness (peaking) of the video input decoder. This setting only affects the composite and S-Video inputs. It is adjustable from 0dB to 6dB in four steps. The peaking is centered around 2.64MHz. This can be used to correct for a poor video input signal, or to increase the peaking of the output when driving a poor monitor. Note: the output may flicker when changing this setting. This is normal.

Video Standard:

This submenu is used to select the video input standard. The possible selections are:

Auto Detect - Automatically detect the type of video input

NTSC - Only accept NTSC video inputs

NTSC 4.43 - Only accept NTSC 4.43 video inputs

PAL - Only accept PAL video inputs

PAL (M) - Only accept PAL (M) video inputs

PAL (Nc) - Only accept PAL (Nc) video inputs

SECAM - Only accept SECAM video inputs

This setting should normally be left in *Auto Detect*, and the converter will adjust for the input. If the converter is not locking correctly to the input, or it is desirable to ignore certain standards, they can be selected manually.

Video Input:

This submenu is used to select the video input connector used by the converter. The possible selections are:

Auto Detect - Scroll through all the inputs and lock on the first one detected

Composite Input - Only use the composite input

S-Video Input - Only use the S-Video input

Component YUV Input - Only use the component input with a YUV signal

Component RGB Input - Only use the component input with an RGB signal

Component RGBS Input - Only use the component input with an RGBS signal

Normally this setting should be left in *Auto Detect*, and the converter will use the first active video signal it finds. If there are multiple video sources connected to the converter, the desired input can be manually selected. Note, the component RGB and RGBS inputs can not be detected automatically, and must be selected manually.

System Settings Menu:

This menu is entered from the *Idle Menu* by selecting it with the Select Control. Once in the *System Settings Menu*, specific aspects of the converter are set. Settings in this menu are system wide. The following submenus are available from the *System Settings Menu*:

LCD Brightness:

This submenu is used to set the brightness of the front panel LCD. It can be set from 25% to 100% brightness.

LCD Contrast:

This submenu is used to set the contrast of the front panel LCD. It can be set from -50 to +50. It should be set for the best contrast on the front panel display.

LCD Dimming:

This submenu is used to set the automatic *LCD Dimming* function. When *Enabled*, if no user activity happens for one minute, the LCD will automatically dim. This can be helpful when viewing a television in a dimly lit room so the LCD will not be as bright.

Menu Timeout:

This submenu is used to set the automatic *Menu Timeout* function. When *Enabled*, if no user activity happens for one minute, the converter will automatically return to the *Idle Menu*. If the user desires the menu's to stay active indefinitely, this feature can be *Disabled*.

Power Saving:

This submenu is used to set the *Power Saving* feature. When no video input is detected on the converter for the selected amount of time, the converter will power itself down. This feature is not available when *Converter Bypass* mode is selected. The possible selections are:

Disabled - Converter will never power down automatically

Power Down: 1 Hour - Converter will power down in 1 hour of inactivity

Power Down: 2 Hours - Converter will power down in 2 hours of inactivity

Power Down: 4 Hours - Converter will power down in 4 hours of inactivity

Power Recovery:

This submenu is used to set the *Power Recovery* feature. When enabled, the converter will return to the previous power state after a power failure. For instance if the power goes out and then comes back on, the unit will power back up, and return to the previous operating state. If this feature is disabled, the unit will remain off until manually powered back on.

Language:

This submenu is used to set the *Language* of all menus on the converter. The possible selections are:

English

Deutsch

Francais

Espanol

Control Tracking:

This submenu is used to set the *Control Tracking* function. When *Enabled*, a speed sensitive tracking feature is applied to the Controls. This means the faster the Controls are turned, the more effect they have. This is very useful on many of the menus which have a very large adjustment range. For example, *Video Contrast* is adjustable from 0.000 to 1.990. By turning the Control fast, the adjustment will occur more quickly. By turning the Control slowly, very fine control over the adjustment can be obtained.

When *Disabled*, no speed sensitive tracking is applied and the Controls will have the same affect regardless of how fast or slow the Control is turned.

Control Swap:

This submenu is used to swap the function of the front panel controls. This is one of the special cases that must be selected by pushing the Select Control. If the user would prefer to have the Menu Control on the right and the Select Control on the left, they can be swapped in this submenu.

Installed Options:

This submenu is for informational purposes only. No user settings are available. In this submenu the user can scroll through a list of installed options in the converter.

System Info:

This submenu is for informational purposes only. No user settings are available. In this submenu the user can scroll through a list of the version numbers and serial number of the converter. This information can be used to make sure the converter has the latest code.

Advanced Settings Menu:

This menu is entered from the *Idle Menu* by selecting it with the Select Control. Once in the *Advanced Settings Menu*, specific advanced aspects of the converter are set. Settings in this menu are system wide. The following submenus are available from the *Advanced Settings Menu*:

Set Defaults:

This submenu is used to return the converter to it's factory default settings. The possible selections are:

- Sys/In/Adv Defaults?* - The System, Input and Advanced defaults are restored
- Output Defaults?* - Only the currently selected standard defaults are restored
- All Defaults?* - All defaults are restored
- User RF Erase?* - Erase User RF Table

Any specific user settings in the affected menus will be lost when the factory defaults are restored. This is one of the special cases that must be selected by pushing the Select Control.

Default Audio:

This submenu is used to select the type of audio when no video input is detected. The possible selections are:

Disabled - No audio output when no video input detected

Test Tone -24dB - A -24dBFS 1KHz sine wave is output when no video detected

Test Tone -18dB - A -18dBFS 1KHz sine wave is output when no video detected

Audio Inputs - The audio inputs are passed through when no video detected

NTSC Reverse 3:2:

This submenu is used to select the *NTSC Reverse 3:2* pulldown detection. NTSC 3:2 pulldown is a process used to broadcast 24fps movies. By detecting this process and reversing it, a perfect reconstruction of the original 24fps media can be obtained. This should normally be left on as it will have no affect on normal video.

VCXO Control:

This submenu is only available when the VCXO option is installed. This option provides a method to lock the converter's output to the video input, yet maintain extremely precise output timing even if the input timing contains jitter. Without this option, or when disabled, the converters output is always stable and jitter free, but frames of video may be added or dropped as needed if the video input clock rate differs from the converters internal clock.

PLL Hold:

This submenu is to select the behaviour of the PLL. When enabled, the PLL will hold it's last value when lock is lost. When disabled, the PLL will return to it's nominal frequency when lock is lost.

User RF Video Modulation:

This submenu is used to set the video modulation type of the User RF System. The possible selections are:

Negative

Positive

User RF Audio Modulation:

This submenu is used to set the audio modulation type, and video/audio channel spacing of the User RF System. The possible selections for the modulation type are:

AM -12dB
AM -6dB
FM -16dB
FM -12dB

And for the carrier spacing are:

----- *Used for full independent AM carrier frequency, no sound trap*
2.25MHz + or - *AM spacing*
2.80MHz + or - *AM spacing*
3.50MHz + or - *AM spacing*
4.00MHz + or - *AM spacing*
4.50MHz + or - *AM spacing, +/- FM spacing*
5.50MHz + or - *AM spacing, +/- FM spacing*
6.00MHz + or - *AM spacing, +/- FM spacing*
6.50MHz + or - *AM spacing, +/- FM spacing*
11.12MHz + or - *AM spacing*

This menu uses a cursor under the section of the menu that is currently selected as shown below:

AM -12dB +4.50MHz

In this example, the cursor is under the carrier spacing setting, so this is what the Select Control will change.

User RF Channel Name:

This submenu is used to create an entry in the User RF System table, and attach a name to it. The menu appears as shown below:

Entry: 5+ Name:XYZ

This menu uses a cursor under the section of the menu that is currently selected. When the “+” is shown in the *Entry* section, the entry has not been created in the User RF table yet. To create the entry, push the Select Control. The last entry in the table can be removed when the “-” is shown by pushing the Select Control. The *Entry* value is strictly used as a position in the User RF table, while the *Name* created in this menu is what will be used to denote the channel. Note: You can only scroll

through the number of active entries in the table, with a maximum of 32 entries.
 Note: the possible values for *Name* characters are as follows:

* + , - . / 0 1 2 3 4 5 6 7 8 9 : ;
 A B C D E F G H I J K L M N O P Q R S T U V W X Y Z
 a b c d e f g h i j k l m n o p q r s t u v w x y z

User RF Video Frequency:

This submenu is used to set the video carrier frequency for the selected entry in the User RF System table. The menu appears as shown below:

345.25MHz

This menu uses a cursor under the section of the menu that is currently selected. The cursor can be positioned under each decade of the frequency, and then adjusted. The frequency will automatically stay within the range of 28.50MHz to 880.00MHz.

User RF Audio Frequency:

This submenu is used to set the audio carrier frequency for the selected entry in the User RF System table. This menu is only available when the “-----” (no carrier spacing) was selected in the *User RF Audio Modulation* menu. The menu appears as shown below:

340.75MHz

This menu uses a cursor under the section of the menu that is currently selected. The cursor can be positioned under each decade of the frequency, and then adjusted. The frequency will automatically stay within the range of 28.50MHz to 880.00MHz.

Quick Settings Menu:

This menu is entered from the *Idle Menu* by turning the Menu Control. This menu contains the most common user settings for quick changes. All settings in this menu are unique for each standard, so making a change in one standard will not affect other standards. The following submenus are available from the *Quick Settings Menu*:

Zoom Image:

This submenu is always available and is used to zoom the video image to correct for 16:9 letterbox images. Television is frequently broadcast at wide screen 16:9 letterbox which does not fit the standard television screen. This control zooms the image to correct for this, typically increasing the actual image resolution.

Pan Image:

This submenu is only available when Zoom Image is enabled, or on some narrow mechanical standards like NBTV and Baird. Since the output video is the cropped center of the input video, this control allows the user to pan the video image back and forth across the entire input image. This control ranges from -100% to +100% relative to the input video.

Freeze Image:

This submenu is always available and is used to freeze the output image.

Frame Phase:

This submenu is only available when a mechanical standard is currently active. It allows the output to be frame “phased” relative to *Reference Input* or the *Reference Output* signal. This is used to align a mechanical image’s frame to the “phase” of the television. The control ranges from 1 to the number of lines in the selected standard.

Line Phase:

This submenu is only available when a mechanical standard is currently active. It allows the output to be line “phased” relative to *Reference Input* or the *Reference Output* signal. This is used to align a mechanical image’s line to the “phase” of the television. The control ranges from 0 to 100%.

Color Phase:

This submenu is only available when an electronic sequential color standard is currently active. It allows the output to be color “phased” by slipping the phase one field forward or backwards each time the Select knob is turned. This control is unitless, so the display will just show “---”.

Output Color:

This submenu is only available when a color electronic or mechanical standard is currently active. For electronic standards, the user can select between “On” and “Off”. This provides a quick way to disable the color portion of an electronic signal.

For mechanical standards, the user can select between “Orange”, “White”, and “RGB”. This only affects the Mechanical RGB output. Selecting “Orange” forces the RGB outputs into a monochrome mode with orange tinting simulating an original NEON lamp color. Selecting “White” forces the RGB outputs into a monochrome mode with no tinting, and selecting “RGB” gives a full, simultaneous color output.

Red Level:

This submenu is only available when an electronic sequential standard or mechanical standard is currently active. It allows the level of the red output, or red fields of an electronic sequential standard to be set from -50 to +50 IRE.

Red Gain:

This submenu is only available when an electronic sequential standard or mechanical standard is currently active. It allows the gain of the red output, or red fields of an electronic sequential standard to be set from 0.000 to 1.995 gain.

Green Level:

This submenu is only available when an electronic sequential standard or mechanical standard is currently active. It allows the level of the green output, or green fields of an electronic sequential standard to be set from -50 to +50 IRE.

Green Gain:

This submenu is only available when an electronic sequential standard or mechanical standard is currently active. It allows the gain of the green output, or green fields of an electronic sequential standard to be set from 0.000 to 1.995 gain.

Blue Level:

This submenu is only available when an electronic sequential standard or mechanical standard is currently active. It allows the level of the blue output, or blue fields of an electronic sequential standard to be set from -50 to +50 IRE.

Blue Gain:

This submenu is only available when an electronic sequential standard or mechanical standard is currently active. It allows the gain of the blue output, or blue fields of an electronic sequential standard to be set from 0.000 to 1.995 gain.

Output Level:

This submenu is only available when a mechanical standard is currently active, and a monochrome device is attached. It is a combination of the individual red, green blue level controls described above. It allows the level of the output to be set from -50 to +50 IRE.

Output Gain:

This submenu is only available when a mechanical standard is currently active, and a monochrome device is attached. It is a combination of the individual red, green blue level controls described above. It allows the level of the output to be set from 0.000 to 1.995 gain.

Save Image:

This submenu is always available and allows the current image to be stored into the Image FLASH. Each standard has it's own image storage area, so one unique image can be stored for each standard. The image will take between 2 and 10 seconds to save. While the image is being save, a progress wheel will be shown on the LCD display, and no other inputs will be accepted.

Hint: you can use the *Freeze Image* function to get the image you like, and then save it to memory.

Default Image:

This submenu is always available and selects the default image to be used when no video input is detected;. The possible selections are:

Black - Video Black

Test1 - Internal Color Bar Generator

Test2 - Startup Promotional Movie

Saved - User Saved Image (only available after an image is saved to memory)

Status Menu:

This menu is entered from the *Idle Menu* by turning the Select Control. This menu is for information purposes only. No user settings are available. The following submenus are available from the *Status Menu*:

Video Input:

This submenu is always available and displays the currently detected video input, both which input is active, and what type of video. The left side contains the information on which input is active, and the right side contains which video standard is detected. The possible information is:

Video In: No Video - No video input currently detected

Input connector information:

CVBS In: - Composite video input selected

Y/C In: - S-Video input selected

YUV In: - Component YUV input selected

RGB In: - Component RGB input selected

RGBS In: - Component RGBS input selected

Input Standard Information:

: *NTSC*

: *NTSC 4.43*

: *PAL*

: *PAL (M)*

: *PAL (Nc)*

: *SECAM*

Additionally the status of the NTSC 3:2 pulldown detector is shown on the right side of this display. If a “3:2” is displayed, it means the converter has locked onto a 3:2 sequence. If the colon between the 3 and 2 is flashing, it means the cadence of the pulldown sequence has changed, and the converter is relocking to the new cadence.

Ref Input:

This submenu is only available when a mechanical standard is currently active and displays the currently detected reference input. The possible information is:

No Input

Line Ref

Frame Ref
60Hz Mains
50Hz Mains

Note, an asterik (*) will appear before the *60Hz Mains* or *50Hz Mains* if the reference is incorrect for the selected standard and the frame rate is being adjusted.

RF:

This submenu is only available when an electronic standard is currently active. The displayed information is as follows:

RF Sys: xxx Chan: xxx

Where *Sys xxx* would show the currently selected RF System, such as A, and *Chan xxx* would show the currently selected channel, such as 1. This would display as:

RF Sys: A Chan: 1

RF V:

This submenu is only available when an electronic standard is currently active, and an *RF System* and *Channel* are currently selected. This submenu displays the frequency and modulation type of the currently selected video carrier. Using the previous example, this would display as:

RF V: 45.00MHz Pos

RF A:

This submenu is only available when an electronic standard is currently active, and an *RF System* and *Channel* are currently selected. This submenu displays the frequency and modulation type of the currently selected audio carrier. Using the previous example, this would display as:

RF V: 41.50MHz AM

Mech Det:

This submenu is only available when a mechanical standard is currently active. The detected device attached to the Mechanical Output or Mechanical Driver Output will

be displayed such as follows:

333ma/RGB

This can be used to validate the correct device is attached to the converter.

Input Voltage:

This submenu is always available and displays the voltage on the input power connector as follows:

Input Voltage: 12.1V

Main Temp:

This submenu is always available and displays the temperature of the main circuit board in degrees Celsius as follows:

Main Temp: 29°C

Driver Temp:

This submenu is only available when the Reference/Current Driver Board option is installed. It displays the temperature of the driver circuit board in degrees Celsius as follows:

Driver Temp: 29°C

If the driver board temperature rises above 45°C, a fan will automatically start. If the temperature rises above 70°C, the driver board will be disabled. If the temperature rises above 75°C, the converter will power down.

Operation

To operate the converter, connect the supplied power adapter to the converter and to the Mains supply. The converter is powered on and off by pushing both the Menu Control and Select Control simultaneously and holding for approximately 2 seconds. The greeting message will be displayed while the converter initializes. This will take approximately 1.5 seconds. During this time all outputs are disabled. Once the converter has finished initializing, the converter will return to the last state it was in. A short promotional video will be displayed for a few more seconds, and then the converter will enter normal operation. Since the factory defaults for each standard are usually the most often required, very few settings need to be changed the first time the unit is powered on for minimal operation.

Minimum operation for electronic standards:

To set the converter up for use with an electronic television, all that needs to be done is to select the desired output standard in the *Output Settings Menu* as previously described. At this point, the converter will be outputting a test image from its composite output connector, and sending the video out the RF connector on the most commonly used RF channel for the selected standard. If the *RF System* or *Channel* are not what is desired, they can be changed in the *Output Settings Menu*.

To connect the converter to the television, the composite video output and audio output can be used to connected to the television if it has line-level inputs, or through its antenna terminals if not. A balance transformer (balun) may be needed to convert the 75 Ω "F" connector output of the unit to the appropriate connector type for the television.

When no video is detected on the video inputs to the converter, the converter will display one of several different test images along with an audio test tone. Built into the converter is a Color Bar Generator, and a short promotional movie. These, along with a user saved image can be selected to be output from the converter when no video input is detected. This can be very helpful in setting up a television and verifying operation with no video source available.

At this point, the test image should now be playing on the television. Specific changes to the operation of the converter to better suite the users needs can be made as described in the previous section.

To connect a video source to the converter, any standard device such as DVD, PVR, VCR or Digital Receiver is typically used. Simply connect the audio and video outputs from the device to the converter. Good quality, 75 Ω cables should be used to connect the video source to the converter. By default, the converter will automatically detect which input the video is connected to, and what standard it is, so no user intervention is required.

The audio from the source device (DVD, PVR, VCR, etc.) should be routed to the converters audio inputs. Two inputs are provided so a stereo audio signal can be fed to the unit. The two channels are combined internally into a monaural signal. If only a

monaural audio source is available, it can be fed to either input. For additional audio gain, a “Y” cable can be used with a monaural source to feed both inputs.

An additional benefit of the converter can be found in its video processing path. Since most early television sets did not have Vertical Blanking Interval Suppression, or Chroma Traps, retrace lines and moire patterns can be visible when using modern video signals. The converter will suppress the VBI signals eliminating retrace lines, and contains a 5 line adaptive comb filter to remove the chroma signal eliminating moire patterns.

Caution! The RF output from the internal modulator uses a double side band modulation technique, and is not suitable for broadcast without filtering. Also, due to the method of frequency division provided in the RF modulator IC's, their outputs are rich in harmonics. It is intended to only be connected directly to a television's antenna input. At no time should the RF output from this unit be connected to an antenna for the purpose of broadcasting the signal. While no damage will result to the unit, it is against the law in most countries to use a modulator in such a manner.

Minimum operation for mechanical standards:

In the same way as electronic standards, the unit is setup in a similar fashion. First select the desired output standard, and attach a video source as previously described.

Because of the nature of mechanical television, a good understanding of how they operate is essential to getting one running. Depending on the type of television, the *Reference Output* from the converter may need to be sent to the phonic coils on the television, or an external reference signal may need to be fed to the *Reference Input* to lock the converter. The video output from the converter will need to be connected to the lamp in the television which may require an external power supply and amplifier.

This can be made easier by use of the optional Reference/Current Driver board. It contains an amplifier capable of driving a phonic coil (matching transformer required) and three current drivers for directly driving a RGB LED array.

The figures below show the typical connections to common mechanical televisions. The Baird Televisor uses an AC/DC motor that is not synchronized to the Mains, but rather uses a phonic coil for synchronization. In this setup, the Reference output from the converter is amplified and driven to the phonic coil. The video output, either monochrome from the *Composite Output* or RGB from the *Mechanical RGB Output* is amplified and driven to the appropriate lamp.

The Western Televisor uses an AC synchronous motor that is synchronized to the Mains supply. This type of television requires a Mains reference to be supplied to the converter so that it can synchronize the video output to the same signal as the motor. This can be supplied through a simple 6VAC or similar Mains transformer. As above, the video output, either monochrome from the *Composite Output* or RGB from the *Mechanical RGB Output* is amplified and driven to the appropriate lamp.

Basic converter connections to mechanical televisions

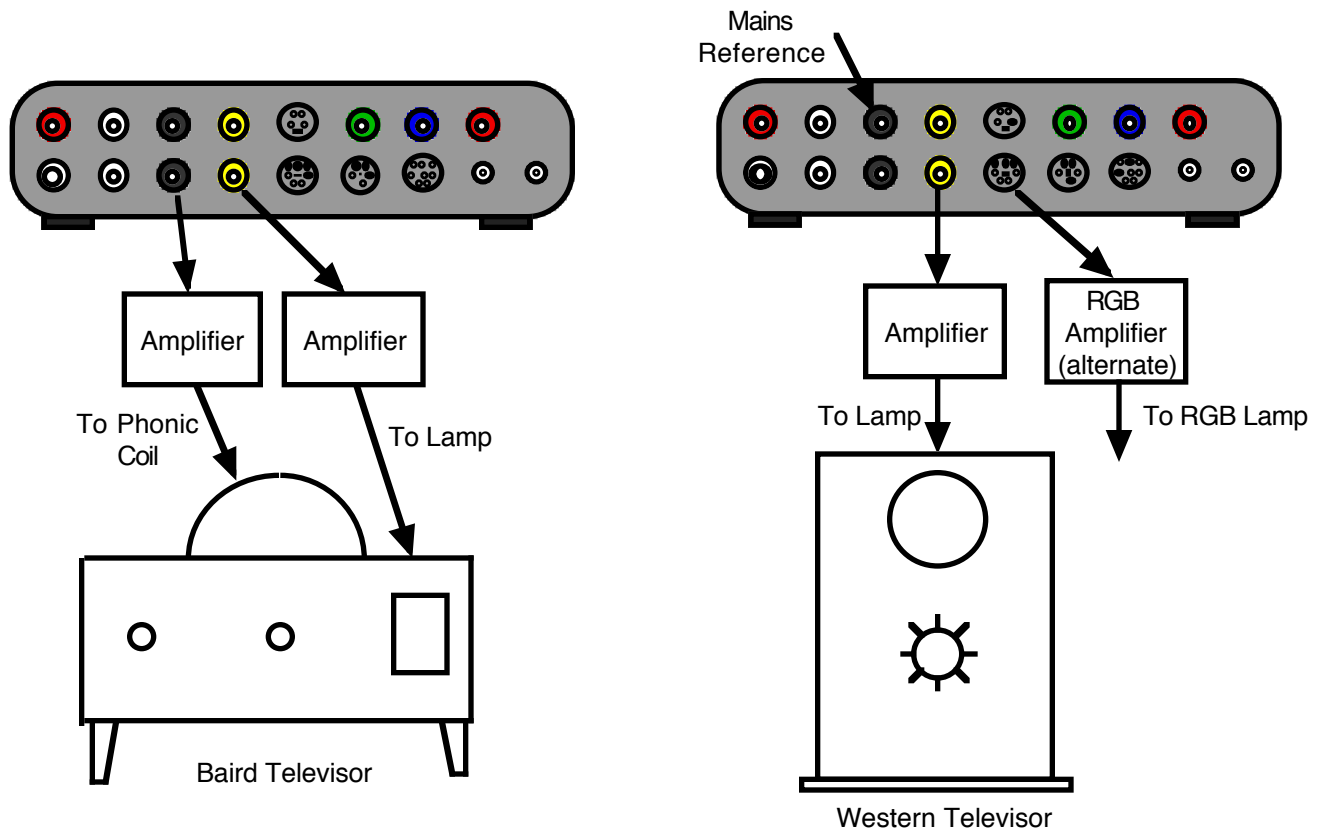

These drawings only represent typical connections to mechanical televisions. Many different types of mechanical televisions were created, and are still being built today by hobbyists. The converter is capable of driving all of these with specific external or internal amplifiers and drivers.

Reference/Current Driver Option

This optional daughter card provides high power outputs for direct connection to mechanical televisions. The Reference Driver provides up to 20W of power to drive a motor, phonic coil, or loud speaker. The Current Driver provides three 333ma current drivers to directly drive an RGB or monochrome LED array. This greatly simplifies connection of the converter to a mechanical television.

If this option was purchased separately, it must be installed into the base converter. To do this, unplug all cables from the converter, and wait at least one minute for all power to bleed off. Next, remove the two screws from the bottom of the converter, and carefully remove the top by pulling straight up on it. Make sure you touch the exposed metal of one of the connectors on the back panel to discharge any static. You will see four standoffs and two dual row connectors that line up with four mounting holes and two dual row headers on the daughter card. Carefully line up the two headers so that all pins are mated. The four mounting holes should line up at this point. If they don't remove the daughter card, and try again. Once the card is aligned, secure it with the four screws supplied.

Caution! Never install or remove the daughter card if the green power LED on the left side of the main board is lit or damage may result to both boards.

Reference Driver Output:

The Reference Driver consists of a Class D switching amplifier for high efficiency. It can provide up to 20W of power into an 8Ω load. The load can range from 6Ω to 12Ω . When driving a load outside this range, and matching transformer must be used. For instance, a Baird Televisor's phonic coil has a characteristic impedance of $11K\Omega$. To match this to the Drivers output, a transformer such as the Hammond 125ESE can be used. Select the $8\Omega/10K\Omega$ taps and connect the primary to the phonic coils and the secondary to the Driver.

The amplifier is protected against over temperature and short circuits. If tripped, the unit may need to be turned off and back on to reset.

A secondary feature of the Driver is the ability to connect a loud speaker and pass the audio through. This is convenient since most mechanical televisions do not have audio facilities. Note: This feature uses a 12 bit codec, so audio quality will be slightly reduced.

Mechanical Current Driver Output:

The Mechanical Current Driver consists of a switching power supply and three current drivers. It is capable of delivering up to 20W into an RGB or monochrome LED array. To drive a monochrome LED, the three outputs can be bridged together.

A unique feature of the Driver is it's ability to Auto Calibrate itself to the load, thus

reducing power dissipation in the converter to a minimum. When first enabling the Driver, or changing its settings, a momentary flash will be observed on the LED. During this flash, the system calculates the load, and automatically adjusts the voltage out to the minimum required. During normal operation, the Drivers are monitored, and if the voltage is determined to be too low due to temperature coefficients or the like, the system automatically adjusts the voltage without interrupting the LED.

This Driver also has a Detect feature that senses a resistor in the cable to notify the converter of what is plugged in. In this way the converter can best setup and limit functions based on the connected device. For instance, if the user creates an LED array that can handle 100ma/channel without damage to the LED's, then it would not be good to allow the Driver to go above the 100ma/channel level. By adding the appropriate resistor in the cable, the converter will automatically limit the current to a safe level. For complete information about this feature, please refer to the *Pinouts* section found later in this manual.

The Reference/Current Driver board contains a fan that will be energized when the temperature of the board rises above a predetermined level. The fan will increase in speed as the temperature increases, and if the temperature can not be controlled (most likely due to an improper load), the Reference/Current Driver will be disabled until the temperature returns to a lower level.

Converter connections to mechanical televisions with Reference/Current Driver Board Installed

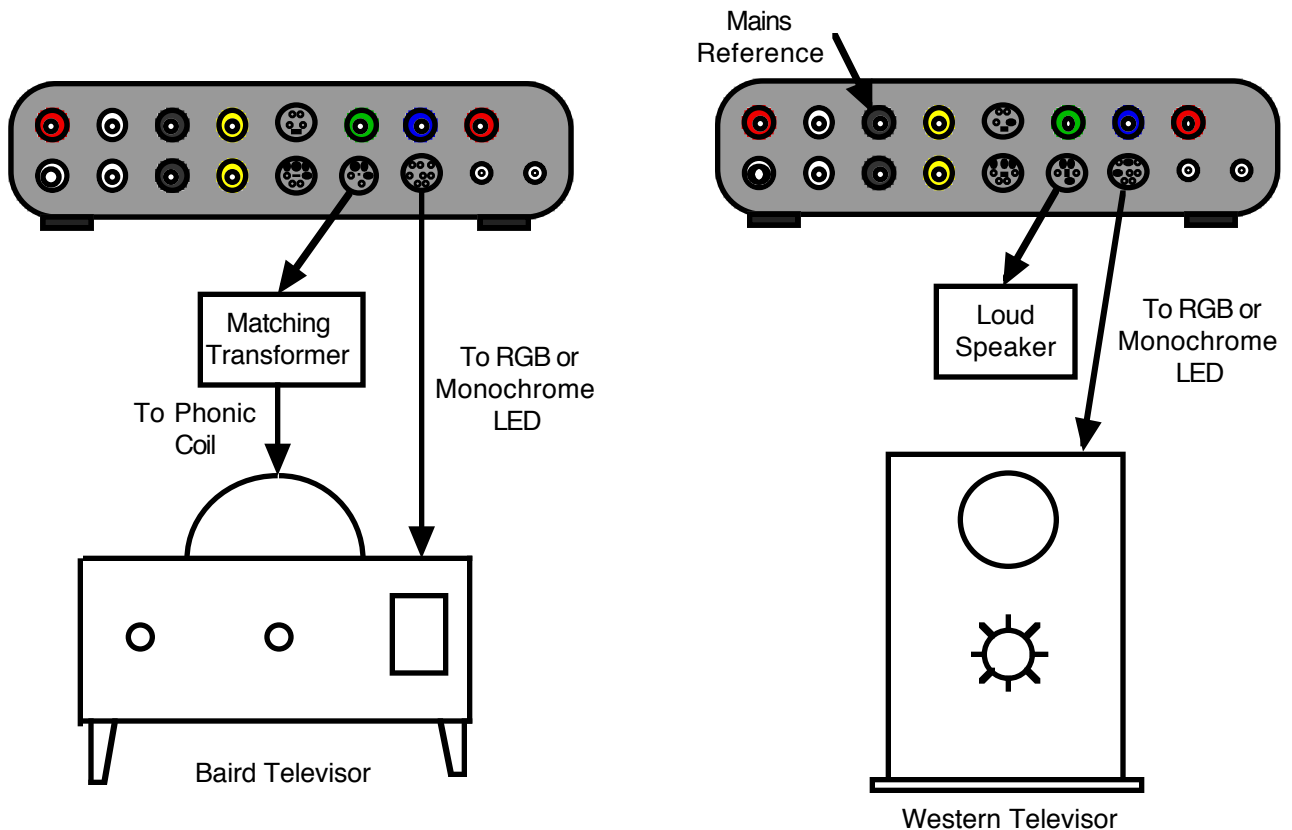

Theory of Operation

In order to convert between different video standards, two main goals need to be realized, spatial correction and temporal correction. The first, spatial correction involves changing the resolution, size and aspect ratio of the incoming video to the output video format. This can be easily achieved through standard digital methods utilizing scalers and FIR filters. The second, temporal correction is much more complex, and involves the use of PLL's and digital techniques to change the rate at which the video is output. Both corrections will be discussed in detail.

It was decided that no off the shelf components existed that would provide the desired functionality, so a FieldProgrammableGateArray, or FPGA, was chosen to provide all the digital processing functionality. By adding input/output circuitry, memory, and ancillary circuitry such as PLL's to the FPGA, the desired system could be realized. A microcontroller and LCD display are used to provide system control and user interface. The basic building blocks to the design are; FPGA, video decoder (ADC), video DAC, video PLL, frame memory, image FLASH memory, audio codec and amplifiers, microcontroller and multiple power supplies. A brief description of each part follows:

FPGA:	Xilinx XC3S500E-5PQ208 500K gate equivalent 360Kb block RAM 1.2V core / 3.3V I/O
Video Decoder:	TI TVP5146M2PFP 10bit ADC's Line Locked Clock Composite, S-Video and Component YUV/RGB inputs 10bit multiplexed YCrCb output bus
Main Video DAC:	TI DAC2932 Dual 12bit DAC 40 MSPS maximum conversion rate 76 db SNR -and- Quad 12 bit DAC 1 MSPS maximum conversion rate
Mech Video DAC:	TI TLV5616 (x3) 12 bit DAC 1.25 MSPS maximum conversion rate 74dB SNR

Theory of Operation

Frame Memory:	Micron MT48LC8M16A2-7E 8M x 16 SDRAM
Image Memory:	Spansion S29GL512P / S29GL01GP-11 32M X 16 / 64M X 16 FLASH ROM
Microcontroller:	Freescale MC9S08JM60CLH 8 bit, 40MHz controller 64KB program FLASH
User Memory:	Atmel AT24C512BN-SH25 512Kb EEPROM 1 Million erase/write cycles Data retention > 200 years
Video PLL:	MicroClock MK1575-01 1.5 - 80MHz range Internal or External Feedback Counters
Audio CODEC:	TI PCM3003T 20 bit ADC/DAC 64X over sampled delta-sigma modulation 90 db SNR 8 - 48 KHz range
RF Modulator:	Freescale MC44BS373CAD (x2, one for video, one for audio) 28.5-880MHz frequency range Automatic Black Level Clamping 76dB μ V Output Level
RF Amplifier:	Analog Devices AD8368ACP -12dB to +22dB gain range 800MHz 3dB point 9.5dB Noise figure

Topology

A block diagram of the circuitry is shown below:

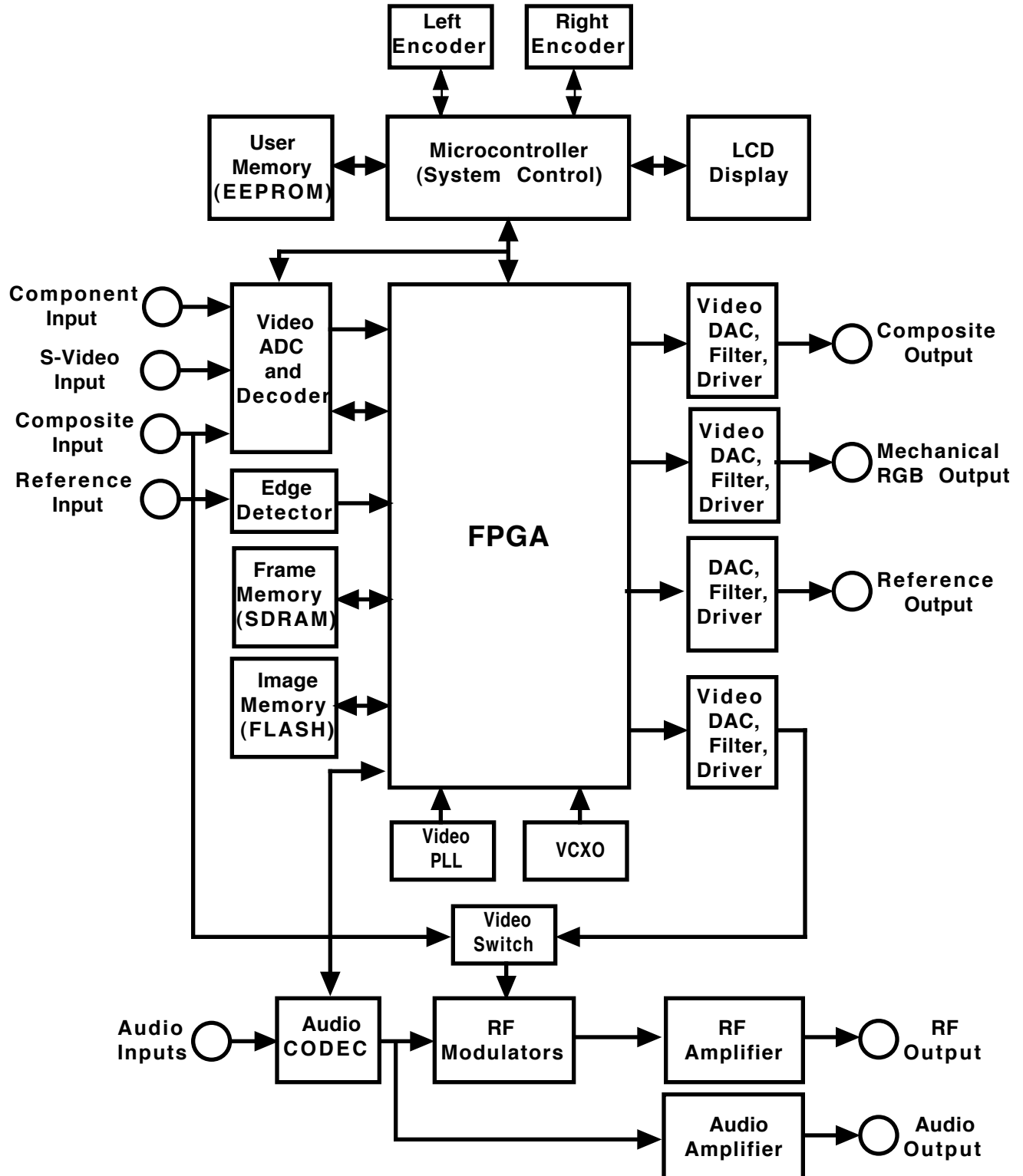

The incoming video is digitized and processed by the TVP5146M2 using a 14.318MHz reference crystal to the ITU-601 (formerly known as CCIR601) specification. The video is quantized, processed for brightness, contrast, chroma gain and hue, among others, and output at the ITU rate of 27MHz on a 10 bit, time multiplexed bus, with alternating luma and chroma samples. No other signals are required from this circuit as the ITU specification describes a method for encrypting the horizontal and vertical timing information directly into the digital data using timing reference makers, or TRS codes. A brief description of the ITU-601/656 specification is as follows:

Fundamental quantization frequency: 13.5MHz
Pixel Resolution: 720 H x 486 V NTSC / 720 H x 576 PAL
Image Aspect Ratio: 4:3
Pixel Aspect Ratio: 1.1 NTSC / 0.9 PAL
Horizontal Frequency: 15,734 Hz NTSC / 15,625 Hz PAL
Vertical Frequency: 29.97 Hz NTSC / 25 Hz PAL
Clocks per Line: 1716 NTSC / 1728 PAL (27MHz clock)
Clocks per Frame: 900900 NTSC / 1080000 PAL (27 MHz clock)

Note that the vertical frequency is 29.97Hz for NTSC, not 30Hz as expected. This is due to the NTSC color system that was first ratified in 1953. All monochrome television transmissions prior to this standard used exactly 30Hz, or 30 frames per second, so as to be in sync with the AC line frequency. This is done to reduce distortions in the image due to induced AC fields or “hum” from the power supplies of these early sets. In order to devise a “compatible” color system that would show a monochrome signal on existing sets, RCA proposed a method of modulating the color components of the video signal onto a subcarrier in the video. For reasons beyond the scope of this manual, a frequency needed to be chosen so that no standing patterns in the color signal would result. This required lowering the vertical frequency from 30Hz to 29.97Hz. While this change caused no adverse side effects on televisions at the time, it has created a legacy of problems for modern video equipment. Instead of being able to use integer numbers like 24, 25 and 30, we now have to include 29.97 which makes many calculations and conversion extremely difficult. For digital processing, the ratio 1000/1001 has been established as the conversion between 30 and 29.97 video.

The digital video data is then routed to the FPGA where it is further processed. It is first passed through a multiple tap FIR filter before horizontal downscaling. The FIR filter is required to remove the high frequency components from the video before downscaling, otherwise alias artifacts would be visible in the downscaled image. The amount of filtering and downscaling is controlled by which output standard is selected. The lowest amount being no filtering or downscaling, to a maximum of 8:1 downscaling. No vertical downscaling is done at this point. The filtered and scaled data is then sent to the frame memory in round robin fashion. The SDRAM frame memory is large enough to hold eight full color, 10 bit per

component video frames, so there are always eight frames of video stored at any given time. All processing is done to the luma and chroma components, with further processing of the color space done from YUV to RGB when required.

All previous processing was done synchronous to the ITU clock, so no additional clocks were necessary. Before any further processing can be done, a new clock, synchronous to the output standard must be generated. The MK1575 is used for this purpose. By running it in its external feedback loop mode, the exact frequency and phase of its output can be determined by programmable counters in the FPGA. Depending on the selected output standard, the appropriate integer numerator and denominator for the PLL are selected. This will be discussed in more detail later.

With this new output synchronous clock, a video timing generator, or flywheel is created in the FPGA to generate all timing signals for the selected output standard. All horizontal, vertical, pixel count and line count generation is done in this process. Additional for electronic standards, frame timing signals in the form of equalization and serration pulses are generated. For sequential color electronic standards, an additional color sequence and “red field” equalization signal is generated. This is the main “heartbeat” process for the entire design.

Using these timing signals, the video data that was stored in the frame memory synchronous to the incoming 27MHz video clock can now be clocked out synchronous to the new output clock. Since the video has already been downscaled horizontally, it only needs to be further downscaled vertically, and frame or field blended before being output to the video DAC.

For mechanical standards, one additional step is taken before outputting the video. Since CRT displays have a characteristic gamma of 2.2, it was decided in the very early days of television to do a 0.45 “gamma correction” at the camera to compensate the image. The result is the brightness on the CRT closely matches the brightness of the original scene. Mechanical sets however use neon, or newer LED replacement lamps for illumination that have a gamma close to 1.0. Because of this, displaying raw video on one of these sets would result in an overall gamma of 0.45 causing the gray levels to be severely distorted. To eliminate this problem, all video goes through a 2.2 “gamma corrector” in the FPGA before being output. This gives the desired 1.0 gamma at the surface of the neon or LED lamp.

With all the above timing now generated, the output video can be generated. The signals from the flywheel are routed to the main video output DAC at the appropriate times in the signal, while the processed video from the frame memory is routed to the video DAC during the active portions of the video signal. The video data is also routed to an IIR filter that acts as a sound trap to eliminate any frequencies that could interfere with the audio carrier of the selected RF System. This processed data is sent to the second video DAC and then to the RF modulators.

In addition to the above, when a mechanical standard is selected, the simultaneous red, green and blue video signals are sent to three separate video DAC's. This allows for full simultaneous color on all mechanical standards.

At the same time, audio from the audio input connectors is quantized at approximately 39KHz, delayed by the appropriate amount of time to offset the delay

of the video due to internal processing, and sent out the audio output connector and the audio RF modulator.

Detailed Analysis

Generating an output clock:

As shown in the previous section, a clock, synchronous to the output standard must be generated. Using standard PLL techniques, it is a simple matter to generate this clock. Below is the block diagram of the PLL circuitry:

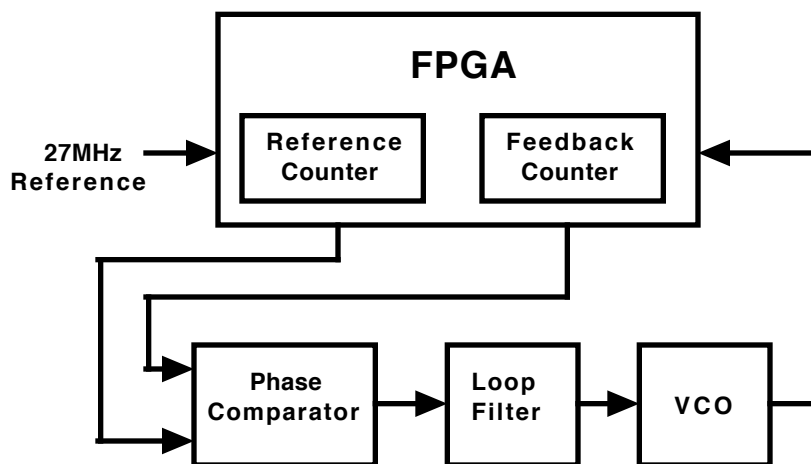

By carefully selecting the Reference and Feedback counter values, the desired synchronous frequency for the selected output standard can be achieved. Using the 405/72i CBS Color standard as an example, the counter values can be calculated as follows:

First, it is desirable to keep this clock near the 40MHz limit of the video DAC's for the best utilization of the available bandwidth. Using this fact, and a target horizontal blanking area of 18%, the best fit for the pixels per line is around 360 for:

$$72\text{fps} * 405 \text{ lines} * 360 \text{ pixels/line} * 1.18 \text{ HBL} = 12.4\text{MHz}$$

Using a 3X clock would yield a 37.2MHz rate, or $360 * 3 = 1080$ clocks for the active horizontal area and $1080 * 18\% = 195$ clocks for the horizontal blanking area, for 1275 clocks total per line.

Knowing there are 900,900 clocks per frame in the NTSC signal, and the frame lasts $1/29.97$ of a second, multiplying by $29.97/71.928$ (output standards conform to the 1000/1001 ratio) yields exactly 375,375 NTSC video clocks per 405/72i frame. Finding the factors of 375,375 yields for the reference counter:

$$375,375 = 3 * 5 * 5 * 5 * 7 * 11 * 13$$

Calculating the number of clocks per frame in the 405/72i output standard yields the feedback counter of:

$$1275 \text{ clocks/line} * 405 \text{ lines} = 516,375 \text{ clocks/frame}$$

Finding the factors of 516,375 yields:

$$516,375 = 3 * 3 * 3 * 3 * 3 * 5 * 5 * 5 * 17$$

Eliminating common terms yields:

$$\frac{\cancel{3} * 3 * 3 * 3 * 3 * 3 * \cancel{5} * \cancel{5} * \cancel{5} * 17}{\cancel{3} * \cancel{5} * \cancel{5} * \cancel{5} * 7 * 11 * 13}$$

Resulting in a final ratio of the reference counter to the feedback counter:

$$\frac{1377}{1001}$$

Using these counter values and the 27MHz NTSC video clock, we can generate a 37.2MHz output clock that has exactly 516,375 clocks per frame, and is in exact synchronism with the NTSC rate.

Generating a QAM (color) clock:

Since this converter can generate QAM color signals, like NTSC and PAL, an extremely stable clock is required. Typically this clock must be no more than a few tens of ppm maximum static error, and less than a few ppm jitter. The above PLL is not low enough jitter for this purpose, so a very high speed (~180MHz), crystal based, stable clock source is used to generate the QAM signal timing, and then down sampled to the output clock. This provides a very accurate, stable way of generating all QAM timing. While this level of accuracy is not required for color signals like SECAM, the same stable clock is used for all composite color signals.

VCXO (optional):

To obtain a very stable, low jitter output from the converter, a fixed crystal oscillator is used as the source for all timing. While this does provide a highly accurate timing source, there will always be a slight difference between this clock, and the clock of the incoming video. This only affects outputs with the same frame rate as the

input, for instance 625/25i to 405/25i. When converting between different frame rates, frames must be created or reduced normally, so the VCXO does not provide any benefit.

Even a small error between these two clocks will result in a drift between the input and output over time that will cause a repeated or dropped frame. For instance, a 50ppm difference between the two clocks will result in a full frame time of error approximately every 11 minutes. This is how even most professional video equipment works, and will usually go completely unnoticed by the viewer. There is a method to completely eliminate this effect at the expense of output accuracy, but not stability.

By using a VCXO, which is a crystal oscillator that can be pulled slightly faster or slower, the main timing source for the converter can be made to match that of the incoming video. As long as the incoming video is within the “pull” range of the VCXO, the system will lock. The stability of the output from the converter will not be affected as it is still based on a very stable crystal source. The accuracy of the output from the converter will now match the incoming video, so it will only be as accurate as the incoming video. For instance, if the incoming video is off by 25ppm from ideal, then the output from the converter will also be off by the exact same amount. Even if this option is present, it can be disabled by the user if optimal output accuracy is desired.

Spatial Correction:

In order to convert between different video standards, the video image must first be spatially converted between the two standards sizes. Many aspects need to be taken into account such as image aspect ratio, and the number of active lines. The distinction of image aspect ratio is made here to differentiate it from pixel aspect ratio which only has to do with how the analog data is quantized.

On first inspection, it would appear that spatial correction can easily be achieved by simple adding or dropping pixels to get the desired result. For example, if you have 720 pixels in the input, and need 360 pixels in the output, dropping every other pixel would appear to be adequate. Unfortunately, half the original information is lost, not being included in the output in any way, and since the input pixels were sampled at a much higher frequency than the pixels are being output, aliasing of the image will occur. To avoid this situation, the pixel data must first be run through a low pass filter to remove any high frequency components above what the output frequency will be, then this filtered data can be resampled for the desired number of output pixels. In the analog world, this is done with a typical low pass filter. In the digital world, this is done with an FIR, or Finite Impulse Response filter. Both achieve the same end result, reduction of the high frequency components.

Now that the data has been filtered, it can be scaled. For most of the electronic output standards this is a relatively easy task since they share a common 4:3 image aspect ratio. Using the 405/72i CBS Color format as an example, we know from the previous discussion that there are 360 active pixels per line, and 405 total lines. Using a vertical blanking area of 10% yields a desired active vertical area of 364 lines. This means that the active area for this standard is 360 x 364 pixels. Since ITU-601 NTSC

has 720 x 486 pixels, we need to scale the horizontal by 2:1 and the vertical by 3:4. A three tap FIR filter is used to eliminate the high frequency components of the original quantized video data, and then sent to a 2:1 scaler.

The data is then sent to the frame memory. During the active video areas in the output video, the data is read out of the frame memory, additionally scaled by 3:4 vertically to arrive at the final output resolution of 360 x 364.

When working on mechanical standards, or any standard that varies from the incoming 4:3 aspect ratio, this also needs to be considered in the scaling of the video. For example, the 240/24p electronic standard has a 6:5 aspect ratio. By targeting 360 X 240 pixels for the output, we come close to the desired standard, with the exception that if this 4:3 image were to be displayed in it's entirety on the 6:5 aspect ratio display, it would appear squeezed horizontally. Because of this, we discard 36 pixels on each line which has the correct 6:5 aspect ratio. Note: the original pixel aspect ratio of 1.1 must be taken into account in this calculation to yield the correct result.

Temporal Correction:

As previously noted, temporal correction can be much more involved than spatial correction. Making the situation even more difficult is that fact that most high definition standards are interlaced. This means that a frame of video can not be handled as a single image since the two fields are actually separated in time. Since each field in the original video is in temporal order, they must stay in the correct temporal order during playback, or severe stuttering or jumping of the images will occur.

There is no perfect solution for rate conversion, as all forms are a trade off between complexity/cost and the quality of the conversion. Many different approaches have been taken to solve this problem, and the best one depends on many different factors. Several different methods are employed by this converter depending on the source of the input video, and the selected standard for the output video.

First, for any standard where the output frame rate matches the input frame rate, i.e. 525/30i NTSC to 343/30i or 625/25i PAL to 405/25i, no correction is required. The video is simply scaled spatially, and formatted to the output standard. Additionally, if the output is an even multiple of the input, i.e. 15 fps output from a 30fps input, simple correction is all that is required. In this case, frames are simply dropped (known as decimation) or blended to achieve the desired output rate. While information in the original video is discarded for the decimation case, (that being the frames that are decimated) it is not missed since the resulting effect is no different then running a camera at a higher shutter speed than the frame rate. As long as each frame being output represent what the image should be at that point in time, the full temporal information can be conveyed.

The second type to consider is when the selected output standard is of the progressive type. In this mode the input video is first decimated or blended on a field basis to achieve the desired output frame rate. While this process can create frames that consist of fields from two different original frames, and would be temporally out

of order if played back to an interlaced standard, the process of de-interlacing, or converting the image to a progressive one, removes this temporal distortion. This is similar to the above method, and while image data from the original video is discarded, no visual loss occurs as long as the outputted frames are temporally correct.

In the most complex scheme, an interlaced electronic output is selected that is not an even multiple of the video input frame rate i.e. 525/30i input to 405/25i output. In this situation, there are several methods that can be employed with varying degrees of success. The first method is to simply have the output video follow the input video at whatever the rate difference is. In this scheme, the output video will switch between input video fields at any arbitrary time in the frame. For instance, if the output is halfway through a field, and the input changes from one field to the next, the output would immediately change. While this is the simplest method, and used by most consumer converters and multi-standard VCR's, due to the way interlaced video works, portions of the output will be temporally out of order, resulting in what looks like stuttering or tearing across the image. Due to of all these factors, this is not a good choice for this converter.

Skipping to the most advanced method which is known as motion estimation, it offers the highest degree of image quality most of the time, but at an enormous cost in complexity and price. In this method, two frames are analyzed by a high speed computer algorithm which attempts to dissect the image into moving and stationary objects. The motion of these moving objects is calculated and their position at an arbitrary point in time calculated. The new frames for the output rate are constructed from this data. As can be seen, this is an extremely complicated process, and can be prone to errors. Many factors can complicate this method such as; what does the object look like; is the background moving, etc. In it's best case, this method can provide excellent results obtaining a smooth, natural looking output. In it's worst case, objects can temporarily disappear, or be placed in the wrong position. Because of all these factors, this is not a good choice for this converter.

The method chosen for this converter is one that provides excellent looking output images, with minimal (usually imperceptible) motion artifacts and image degradation during fast motion. In this preferred method, interpolated fields in the output are made up of combining several fields from the input (known as blending). This allows for extremely smooth and natural looking video, with minimal motion artifacts, and softening of the image. For static or slowly moving images, this method does not degrade the image at all, and for fast moving objects, it has the tendency to decrease the image sharpness very slightly. This is the method used by most professional frame rate converters, and with a proprietary algorithm unique to this converter, provides the best all around image quality and cost of implementation.

There is one more method that can be used when in the NTSC mode of the converter, and exploits a phenomenon unique to the standard. As it turns out, discarding one field every five to yield a desired 24fps or 72fps output rate from the 30fps input will result in no loss of data in most cases. This is due to a fact that was discovered very early in television development, and is described below.

As can be seen by the supported standards of this device, early American electronic television used a 24fps frame rate to match what was typically used by film.

This was done to simplify the broadcasting of films which was the major source of material at the time. Two problems arose using this frame rate. The first is that the frame rate is so low, the perceived flicker in the image is objectionable to a human viewer. It was found early in the development of film projectors that any rate less than about 48fps caused objectionable flicker to a viewer. In film, this problem was solved by placing a “cutter” wheel in front of the lens that spun at twice the rate the film was running at, fooling the viewer into perceiving 48fps. The second problem with using 24fps for electronic televisions is that most AC power grids run at a rate of 60Hz. This means that any stray AC fields, or unfiltered hum that gets through the televisions power supplies will result in rhythmic distortion of the image.

Because of these two issues, it was quickly realized that a higher frame rate would be required, but higher frame rates require equally higher bandwidths. To overcome this new problem, interlaced scanning was devised that draws the image on the screen in two successive passes, typically 60 fields/sec or 30 full frames/sec, fooling the viewer into seeing a higher field rate, but keeping the required bandwidth down. This solved both the flicker and AC interference problems, but now films could not be shown without some kind of conversion. At first it would seem obvious to just duplicate every fourth film frame so that four film frames create five video frames, yielding the desired 24fps to 30fps conversion. (shown below)

4 Film Frames 24 fps

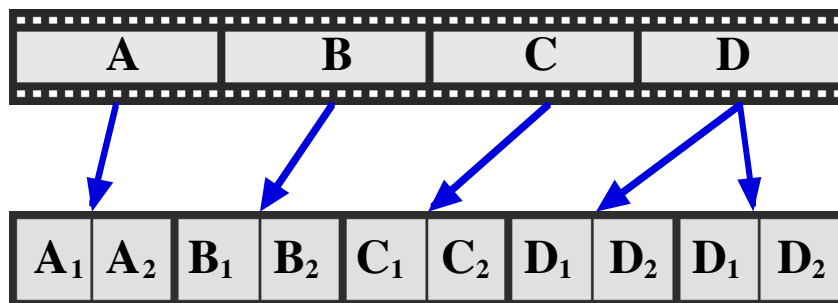

5 Video Frames 30 fps

Unfortunately the human eye is very sensitive to this duplication of images, and this was found to be unacceptable. However, since there are actually 60 fields/sec in interlaced video, a single field every four can be duplicated with much less visibility to the human eye. Since this yields a pattern of 2 fields followed by 3 repetitively, it is called “3:2 pulldown”, and is still how film is shown on NTSC to this day. (shown below)

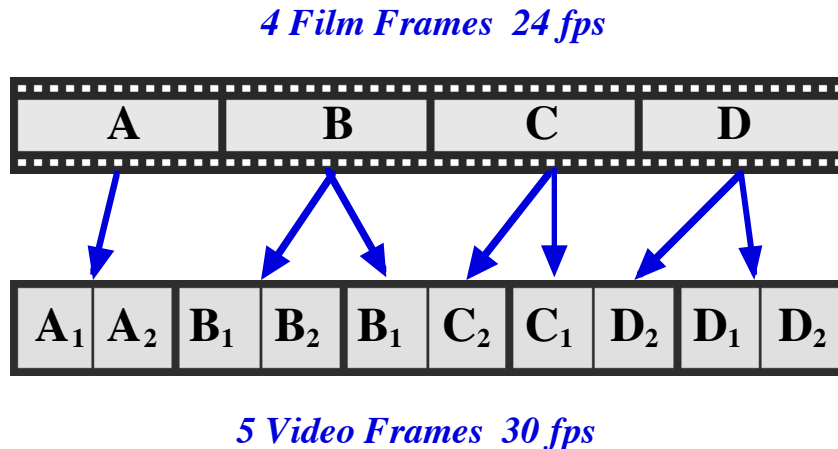

Because 2 fields are identical every 5 fields, (i.e. B₁ and D₂) this process can be detected and removed from the video. By comparing successive fields as they are quantized, the original 24fps film can be completely reconstructed and used for the 24fps based output standards. Because of this process, even though one field is discarded every five fields, no data is lost from the original material.

It should be noted that while this method is very effective at recovering the original 24fps material, it only works if the “cadence” or ordering in which the fields were created is proper, and does not break sequence. This is true of any commercial DVD, or uncut movie on broadcast television. Unfortunately, many network television shows are edited after this 3:2 pulldown process is performed, meaning if the editor is not extremely careful, the cadence will be broken at each edit point. Additionally, to cram more commercials into network television, a method called “time compression” is performed on the original video to speed it up slightly so more commercials can be placed in the broadcast. This has the effect of destroying the cadence of the original material, rendering this method totally ineffective. When this happens, the output image will appear to stutter, and then smooth out repeatedly as it obtains and then loses cadence lock.

RF Modulator:

Due to limitations in the currently available RF Modulator IC’s, two IC’s are used with their outputs combined before being sent out the RF connector. This arrangement allows for positive and negative video modulation coupled with AM and FM audio modulation. Further, in the case of AM audio, any carrier separation between the audio and video can be achieved. The FM audio carrier is limited to +/- 4.5, 5.5, 6.0 and 6.5MHz from the video carrier.

The reference clock for both modulators is derived from a process in the FPGA. This way no external crystals are required, and both modulators are locked to the

same frequency. This reference clock is used by the modulators for an internal PLL with an external loop filter. High quality film capacitors are used in the loop filter to minimize microphonics as is the case with any ceramic capacitor.

The microcontroller programs the modulators as to frequency, modulation type, etc. The video modulator receives its input from a switch that allows the microcontroller to route video from the converter output, or from the composite video input connector. The video modulator contains a DC restorer circuit that sets the correct carrier levels.

Audio from the two audio connectors is combined, digitized, and delayed to match the video before being sent to both modulators. For FM audio, the same modulator that is used for the video is enabled, and the carrier spacing set. For AM audio, the audio section in the video modulator IC is shut down, and the audio is fed to the video input of the second modulator IC. Feeding the output of the audio section directly into the video input of the second modulator overrides the internal DC restorer. This allows full control over the AM audio, including initial level and depth.

The initial carrier level is set by adjusting the DC offset at the factory. Modulation depth is set by the audio gain control in the *Advanced Settings Menu*.

The outputs of the two modulators are then combined through a balanced network that maintains a 50Ω impedance and sent to the RF amplifier. This amplifier provides a 32 dB range of adjustment to the RF output. Lower levels are good for verifying the RF capability of a television, while high levels are good for driving particularly “deaf” sets, or multiple sets through a passive splitter network.

Reference functionality:

For electronics standards, the *Reference Input* provides no functionality. The *Reference Output* can be used to send a Field or Frame pulse to an external device such as an oscilloscope for synchronization. In this mode, the reference signal is a high speed, 3.3V digital signal.

For mechanical standards, the *Reference Input* is used to synchronize the converter to external sources. Because of the nature of mechanical television, the video driving the lamp must sometimes be synchronized to the motor. If the motor is a Mains synchronous device, than feeding a Mains reference onto the converter will keep it locked to the same signal as the motor. This input can also lock to Line or Frame pulses, like those from a feedback loop in a disk.

The *Reference Output* can provide Line, Frame and Mains square wave and sine wave signals. The square waves can be used to trigger a modern phase locked loop system to keep the motor in sync with the converter. The sine wave signals can be used to drive a motor or phonic coil on the television to keep it in sync with the converter.

Specifications: Base Converter

Video Input:

Supported Standards: NTSC 29.97fps / PAL 25fps / SECAM 25fps

Video Quantization: 10bit A/D, 10 bit data

Video Input: Composite - 1Vpp, 75 Ω impedance
S-Video - 1Vpp, 75 Ω impedance
Component - 1Vpp 75 Ω impedance

Video SNR: 54dB

Video Output:

Video Output: Composite - 1Vpp into 75 Ω

Video Quantization: 12 bit D/A

Video Levels: +/- 3% of output standard

Video Timing: +/- 50 ppm, < 2ns jitter typical

Video SNR: 68dB typical

Video Bandwidth: 9.0MHz -3dB

Mechanical RGB Output:

Video Output: RGB - 1Vpp into 75 Ω

Video Quantization: 12 bit D/A

Video SNR: 68dB typical

Video Bandwidth: 0.75MHz -3dB

Audio I/O:

Audio Sample Rate:	39.0KHz
Audio Quantization:	20 bit
Audio Input:	Unbalanced, > 20K Ω impedance -10dBV nominal input level 0.2Vpp to 5Vpp maximum
Audio Output:	Unbalanced, < 100 Ω impedance 5Vpp maximum
Audio Response:	20Hz to 16KHz, +/- 2db
Audio SNR:	> 85db typical

Reference I/O:

Reference Input:	Unbalanced, >10K Ω impedance 20Vrms maximum 0.0 to 3.0V adjustable threshold
Reference Output:	Unbalanced, 75 Ω impedance 3.0Vpp maximum

RF Output:

RF Output:	66dB μ V to 98dB μ V typical into 75 Ω Crystal/PLL frequency generation
Video SNR:	62dB typical
Modulation Depth:	99% maximum
Audio SNR:	54dB typical

General:

Dimensions:	6.00"W X 4.25"D X 1.50"H (152mm X 108mm X 38mm)
--------------------	--

Specifications

Weight:	12oz (340g)
Power Requirements:	2.1mm X 5.5mm center positive connector 7.5-20Vdc 3.0 watts typical (base converter only), >90% efficiency 45 watts maximum (with optional Reference/Current Driver under maximum load)
Switched Power:	2.5mm X 5.5mm center positive connector 4A maximum
Humidity:	20% - 80% non-condensing
Temperature:	10C - 40C ambient (50F - 104F)

Specifications: Reference/Current Driver option

General:

Reference Driver:	Class D switching amplifier >90% efficiency 6 Ω to 12 Ω load range 20W maximum into 8 Ω (20V input voltage)
Current Driver:	Triple current output 3 X 333ma maximum 1 X 1000ma maximum (bridge mode) Built in 1.5A switching supply, >90% efficiency
Weight:	4oz (114g)
Power Requirements:	10-20Vdc 44 watts maximum (dependent on load)
Humidity:	20% - 80% non-condensing
Temperature:	10C - 40C ambient (50F - 104F)

Supported Output Standards

- 819/25iE 4:3 interlaced electronic (France, 1949-1983)**
- 819/25iF 4:3 interlaced electronic (Belgium, 1949-1983)**
- 625/25i 4:3 interlaced electronic (PAL, 1950-Present) [PAL, PAL(Nc), SECAM]**
- 567/25i 4:3 interlaced electronic (Philips Denmark experimental 1948-1949)**
- 525/72i 4:3 interlaced electronic (GE U.S.A. experimental, 1946) [seq]**
- 525/30i 4:3 interlaced electronic (NTSC 1941-Present) [NTSC, PAL(M), seq]**
- 455/25i 4:3 interlaced electronic (Germany/France, 1935-1956)**
- 441/30i 4:3 interlaced electronic (RMA U.S.A., 1937-1941)**
- 441/25i 6:5 interlaced electronic (Germany/France, 1935-1956)**
- 405/72i 4:3 interlaced electronic/mechanical color (CBS U.S.A. 1950-1953) [seq]**
- 405/25i 4:3 interlaced electronic (EMI, U.K., 1950-1984) [NTSC, PAL, SECAM]**
- 405/25i 5:4 interlaced electronic (EMI, U.K., 1936-1949)**
- 375/25i 6:5 interlaced electronic (France/Italy, 1935-1936)**
- 343/30i 4:3 interlaced electronic (RCA U.S.A. experimental, 1934-1936)**
- 300/24p 4:3 progressive electronic (Don Lee U.S.A. experimental, 1936-1939)**
- 240/25p 4:3 progressive electronic hybrid (Baird, U.K., 1936)**
- 240/24p 6:5 progressive electronic (RCA U.S.A. experimental, 1933-1934)**
- 180/25p 6:5 progressive electronic (TeKaDe, 1934-1939)**
- 180/24p 6:5 progressive electronic hybrid (RCA U.S.A. experimental, 1932)**
- 120/25p 4:3 progressive mechanical (TeKaDe/Fernseh-A.G., 1932)**
- 120/24p 6:5 progressive electronic hybrid (RCA U.S.A. experimental, 1931-1932)**
- 96/25p 4:3 progressive mechanical (Telefunken Germany, 1932)**
- 96/20p 6:5 progressive mechanical (Pioneer Mercantile U.S.A., 1932)**
- 90/25p 4:3 progressive mechanical (TeKaDe, 1932)**
- 80/15p 1:1 progressive mechanical (Don Lee U.S.A., 1931-1935)**
- 60/25p 4:3 progressive mechanical (France, 1935)**
- 60/20p 6:5 progressive mechanical (RCA/Jenkins U.S.A., 1930-1934)**
- 60/12.5p 3:7 progressive mechanical (France, 1932)**
- 50/25p 4:3 progressive mechanical (Marconi experimental, 1932)**
- 48/25p 4:3 progressive mechanical (Germany, 1932)**
- 48/20p 6:5 progressive mechanical (GE U.S.A., 1931)**
- 48/15p 6:5 progressive mechanical (Jenkins U.S.A., 1928-1931)**

Supported Output Standards

45/15i 1:1 triple interlaced mechanical (Western Television U.S.A., 1929-1932)

39/12.5p 4:3 progressive mechanical (Germany, 1932)

32/12.5p 2:3 progressive mechanical hybrid (NBTv, 1995-Present)

30/16.6p 4:3 progressive mechanical (France, 1932)

30/12.5p 4:3 progressive mechanical (TeKaDe Germany, 1930)

30/12.5p 3:7 progressive mechanical (Baird, U.K, 1928-1932)

24/20p 6:5 progressive mechanical (GE U.S.A. experimental, 1928)

Note: “[]” denotes supported electronic color formats. All mechanical standards support simultaneous color.

Supported RF Systems

- System A (UK, Ireland) [Pos, AM], channels 1 thru 14**
- System B1 (Western Europe) [Neg, FM], channels 1 thru 12**
- System B2 (Italy) [Neg, FM], channels A thru H1**
- System B3 (Australia) [Neg, FM], channels 0 thru 12**
- System B4 (New Zealand) [Neg, FM], channels 1 thru 11**
- System B5 (Morocco) [Neg, FM], channels 4 thru 10**
- System B6 (East Germany) [Neg, FM], channels 1 thru 11**
- System C (Belgium) [Pos, AM], channels 1 thru 12**
- System D1 (Russia) [Neg, FM], channels 1 thru 12**
- System D2 (China) [Neg, FM], channels 1 thru 5**
- System E (France, Monaco) [Pos, AM], channels 2 thru 12**
- System F (Belgium), [Pos, AM], channels 1 thru 12**
- System G1 (Europe, Asia) [Neg, FM], channels 21 thru 69**
- System G2 (Australia) [Neg, FM], channels 28 thru 69**
- System H (Belgium) [Neg, FM], channels 21 thru 69**
- System I (UK, Ireland) [Neg, FM], channels A thru 69**
- System K (French Terr.) [Neg, FM], channels 4 thru 69**
- System L (France) [Pos, AM], channels 1 thru 69**
- System M1 (North America) [Neg, FM], channels 1 thru 18**
- System M2 (North America) [Neg, FM], channels 1 thru 83**
- System M3 (Japan) [Neg, FM], channels 1 thru 83**
- System N (South America) [Neg, FM], channels 14 thru 83**
- System X1 (NTSC/AM 1941-46) [Neg, AM], channels 1 thru 18**
- System X2 (RMA 1938-41) [Neg, AM], channels 1 thru 19**
- System X3 (RMA 1936-38) [Neg, AM], channels 1 thru 18**
- System X4 (RCA 1934-36) [Neg, AM], channels 1 thru 9**
- System X5 (RCA 1931-32) [Neg, AM], channels A thru D**
- System X6 (Berlin 1939-1943) [Pos, AM], channels B1, B2**
- System X7 (Paris 1938-40) [Pos, AM], channels F1**
- System X8 (Paris 1948-49) [Neg, FM], channels 1**
- System X9 (GE 1946) [Neg, AM], channels 1 thru 31**

Supported RF Systems

System USR (User Custom), up to 32 channels

Note: “X” Systems were experimental used before the present naming convention.

Pinouts

Most connectors on the converter are industry standard, and therefore follow industry standard pinout. The three mechanical Mini-DIN connectors are custom pinout as follows:

Mechanical RGB Output:

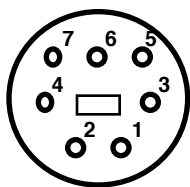

- 1 - Detect
- 2 - Ground
- 3 - Ground
- 4 - Ground
- 5 - Green Output
- 6 - Red Output
- 7 - Blue Output

Reference Driver Output:

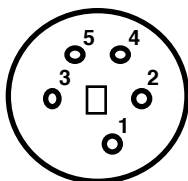

- 1 - Ground
- 2 - Positive Output
- 3 - Negative Output
- 4 - Positive Output
- 5 - Negative Output

Mechanical Current Driver Output:

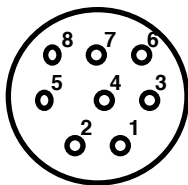

- 1 - Detect
- 2 - Ground
- 3 - Green Output
- 4 - Red Output
- 5 - Blue Output
- 6 - Green Power
- 7 - Red Power
- 8 - Blue Power

Detect Table:

The mechanical outputs use a detection scheme that allows the converter to know what is plugged into the connector. By providing a 1% resistor from the detect pin to

ground, the converter will make the appropriate settings for the connected device. The currently defined devices are as follows:

- 0 Ω - Monochrome NEON driver (external)
- 205 Ω - RGB NEON driver (external)
- 374 Ω - 50ma/channel Monochrome LED
- 560 Ω - 75ma/channel Monochrome LED
- 787 Ω - 100ma/channel Monochrome LED
- 1.05K - 150ma/channel Monochrome LED
- 1.37K - 225ma/channel Monochrome LED
- 1.78K - 333ma/channel Monochrome LED
- 2.26K - 50ma/channel RGB LED
- 2.94K - 75ma/channel RGB LED
- 3.83K - 100ma/channel RGB LED
- 5.11K - 150ma/channel RGB LED
- 7.15K - 225ma/channel RGB LED
- 10.8K - 333ma/channel RGB LED
- 19.6K - unrestricted RGB LED*
- open - Mechanical Current Driver Disabled

*This mode disables the Auto Calibration mode and operates the internal switching supply at full power. This can result in a large amount of power dissipated in the converter which may cause thermal shut down.

Menu Structure

Idle Menu

(displays current standard)

Quick Settings Menu

(from Idle turn Menu Control)

Zoom Image
Pan Image
Freeze Image
Frame Phase
Line Phase
Color Phase
Output Color
Red Level
Red Gain
Green Level
Green Gain
Blue Level
Blue Gain
Output Level
Output Gain
Save Image
Default Image

Status Menu

(from Idle turn Select Control)

Video Input
Ref Input
RF System/Channel
RF Video Carrier
RF Audio Carrier
Mech Detect
Input Voltage
Main Temp
Driver Temp

Output Settings

Output Standard
RF System
RF Channel
RF Gain
Color Type
Ref Input Type
Ref Input Threshold
Ref Output Type
Ref Driver
Mech Current Driver
Gamma Correction
Output Polarity
Line Scan
Frame Scan
Switched Power

Input Settings

(from Idle push Select Control then select menu)

Audio Gain
Video Brightness
Video Contrast
Video Chroma
Video Hue
Video Sharpness
Video Standard
Video Input

System Settings

LCD Brightness
LCD Contrast
LCD Dimming
Menu Timeout
Power Saving
Power Recovery
Language
Control Tracking
Control Swap
Installed Options
System Info

Advanced Settings

Set Defaults
Default Audio
NTSC Reverse 3:2
VCXO Enable
PLL Hold
User RF Video Mod
User RF Audio Mod
User RF Channel Name
User RF Video Freq
User RF Audio Freq

Revision History

Revision 2.2/2.0, 26 August 2010:

- 1) Updated for compatibility with 2.x hardware.
- 2) Corrected error in 120/25p mechanical standard.

Revision 1.8:2.1/1.8, 1 January 2010:

- 1) Added PLL Hold control.
- 2) Changed Reference Input behaviour to force output to match AC Mains frequency. This means the output frame rate will be adjusted to match the AC Mains frequency better matching standard AC synchronous motors.
- 3) Updated French and Spanish language text strings.

Revision 1.7:2.0/1.6, 2 August 2009:

- 1) Added RMA 1934-1936 RF System.
- 2) Increased SDRAM performance from 84MHz to 90MHz.

Revision 1.6/1.6, 17 June, 2009:

- 1) Added 525/72i electronic sequential color standard for 1946 General Electric color television.

Revision 1.5/1.5, 12 May, 2009:

- 1) Split *Advanced Settings Menu* into *Input Settings Menu* and *Advanced Settings Menu* for better clarity.
- 2) Added Sharpness (luma peaking) control to video input.
- 3) Added Control Tracking feature to make entry of large changes easier.
- 4) Corrected error in video modulation type setting for User RF System.
- 5) Corrected error that could cause the User RF System to not be restored properly on power up.

Revision 1.4/1.4, 10 March, 2009:

- 1) Added 300/24p electronic standard for Don Lee system.
- 2) Improved edge rate control.
- 3) Improved mechanical DLL/PLL performance.
- 4) Changed behaviour of Mechanical Current Driver to remember it's settings for each standard even if the load is removed.
- 5) Increased startup speed.

Revision 1.3/1.3, 03 February, 2009:

- 1) Greatly reduced amount of calculations required to add a new standard.
- 2) Improved sync edge rate control.

Revision 1.2/1.2, 18 December, 2008:

- 1) Improved responsiveness of front panel rotary encoders.
- 2) Increased SDRAM performance from 66MHz to 84MHz to better handle higher performance/resolution standards.
- 3) Improved noise immunity on Reference Input.
- 4) Corrected timing error on 567/25i standard.
- 5) Split 819/25i standard into 819/25iE (French) and 819/25iF (Belgian) standards to exactly replicate the timings of each.

Revision 1.1/1.1, 20 November, 2008:

- 1) Added ability to read hardware version from System Menu.
- 2) Increase the possible number of QAM tables for each standard from 3 to 5.
- 3) Added NTSC (M) to 625/25i standard and PAL (B/G) to 525/30I standard.
This allows users to operate a color set designed for a different region and mains frequency on the local mains without inducing hum bars. Since these chroma subcarrier frequencies are not ideal for the mains frequency they will be operated on, some artifacts may appear.

Revision 1.0/1.0, 24 September, 2008:

- 1) Initial release.